

Abmessungen | Dimensions | Dimensioni | Medidas | Dimensions

L	Converter
1000 mm	14,4W / 1000mm
2000 mm	
3000 mm	
4000 mm	
6000 mm	
8000 mm	
10000 mm	

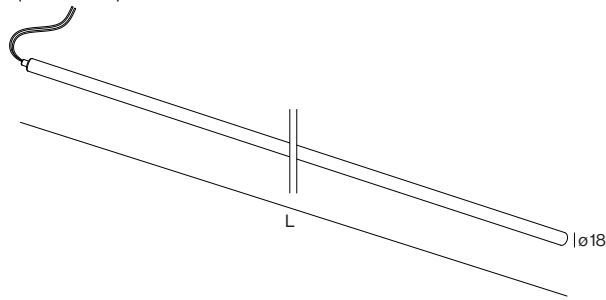

Benötigte Werkzeuge | Required tools | Strumenti necessari | Herramientas necesarias | Outils nécessaires

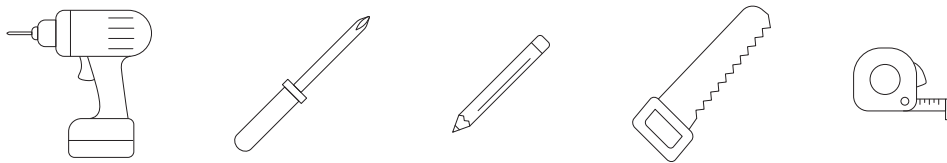

Mounting accessories

Converter suspended

ø50



Converter surface

ø80



Mounting set recessed

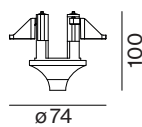

Mounting set surface

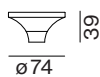

Mounting ring surface

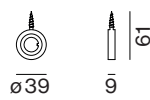

Mounting set suspended

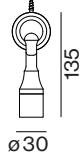

Mounting ring suspended

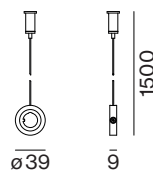

Clip surface

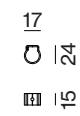

Channel surface

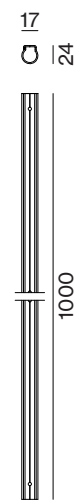

Converter surface

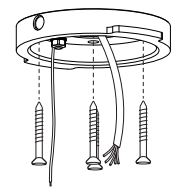
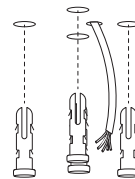
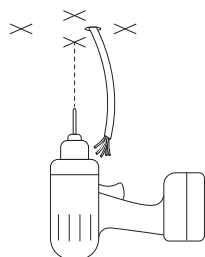
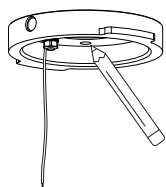

JANE semi-recessed | surface | suspended



Mounting instructions

468202103310

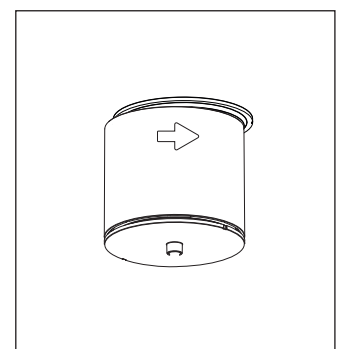
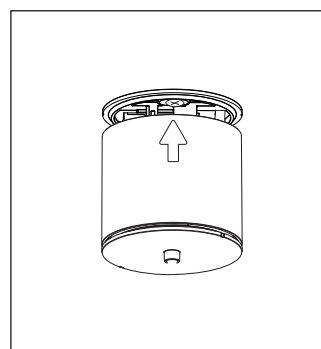
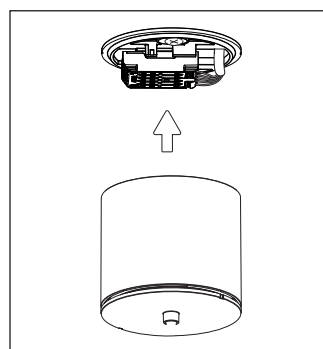
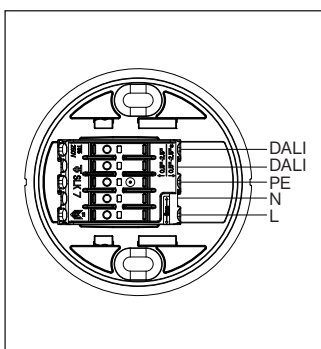
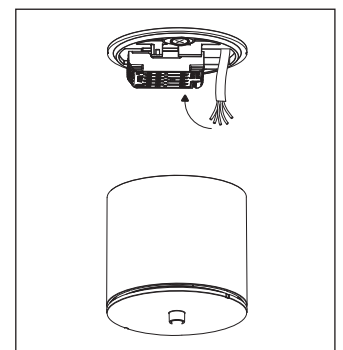
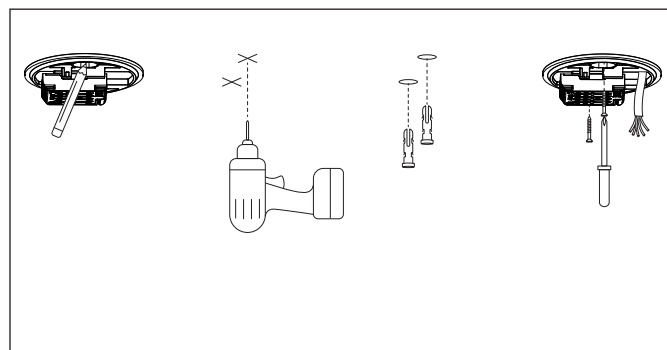
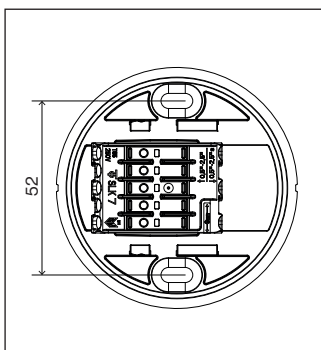
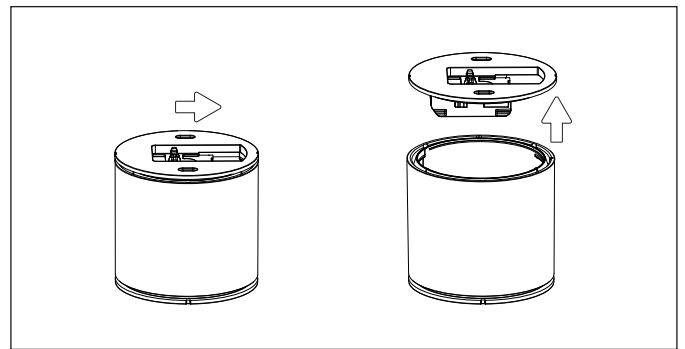
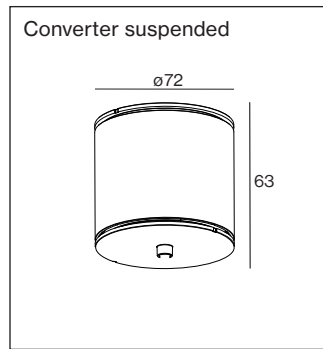
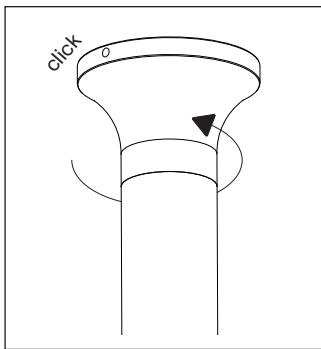
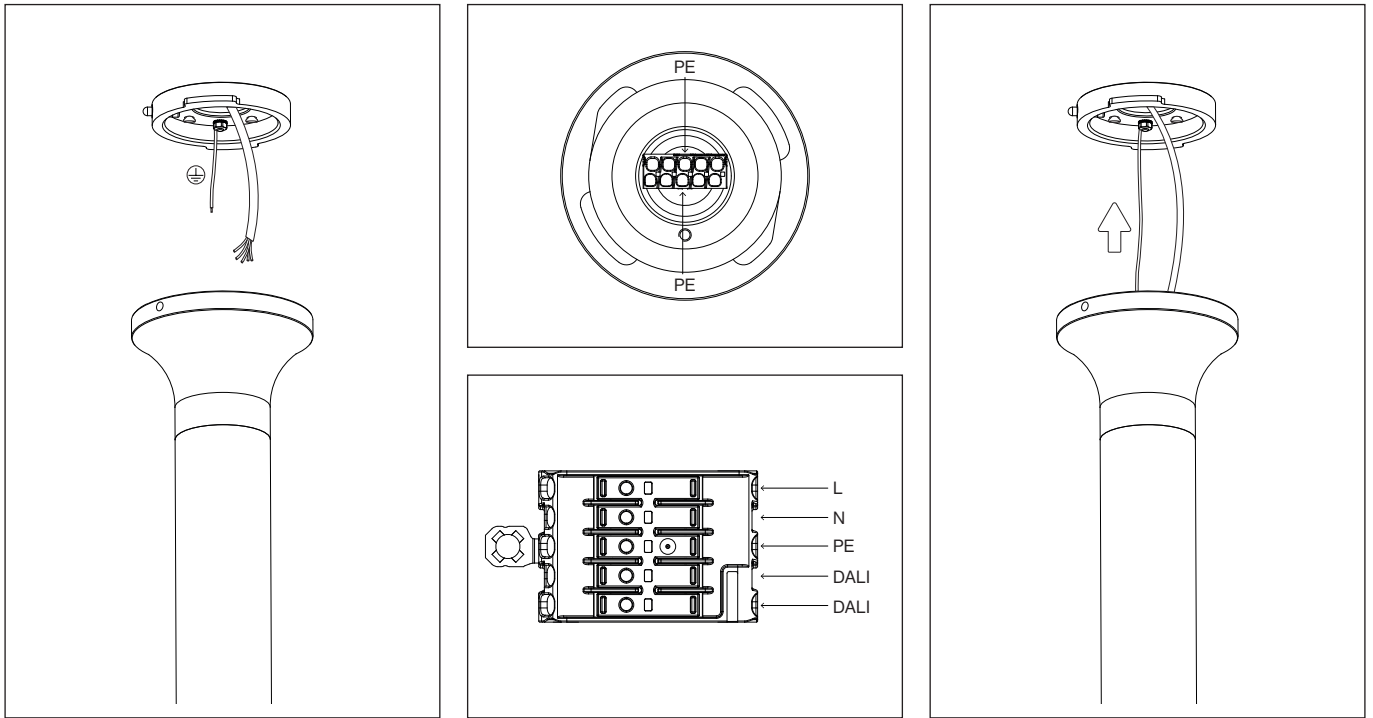

JANE semi-recessed | surface | suspended



Mounting instructions

468202103310

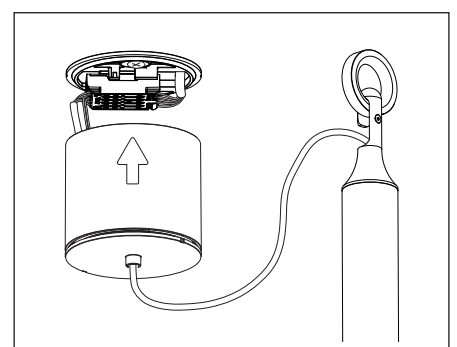
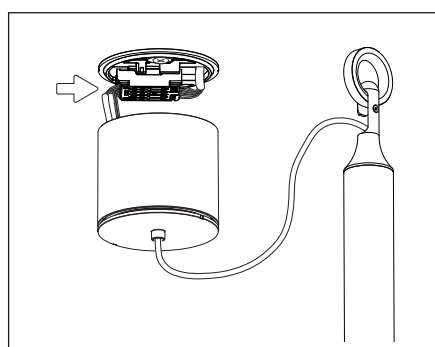
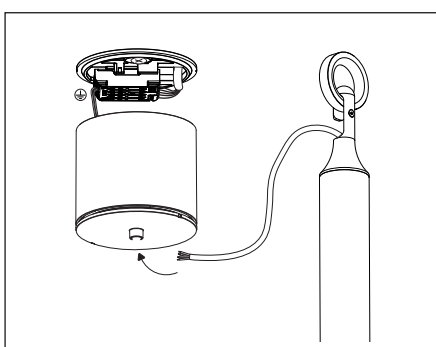
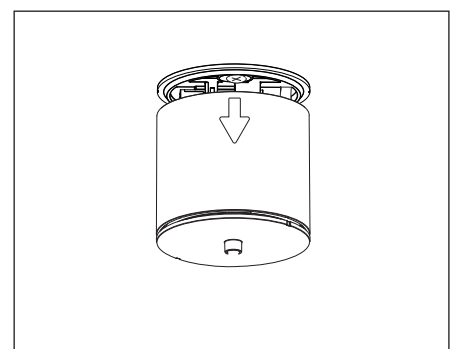
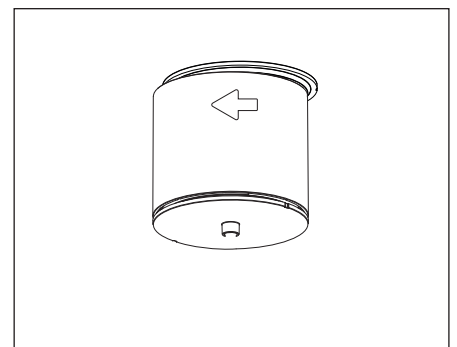
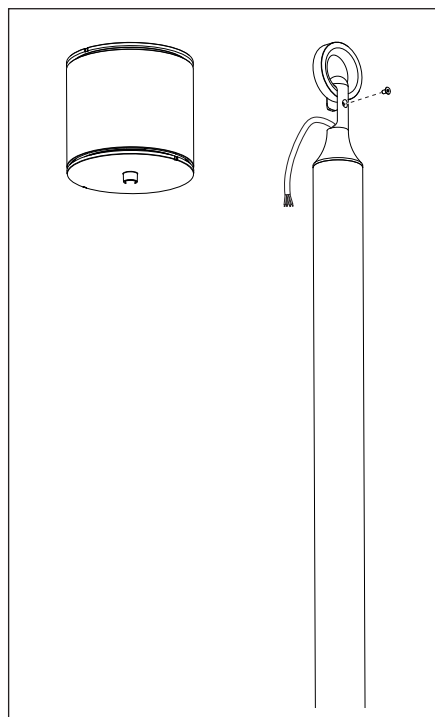
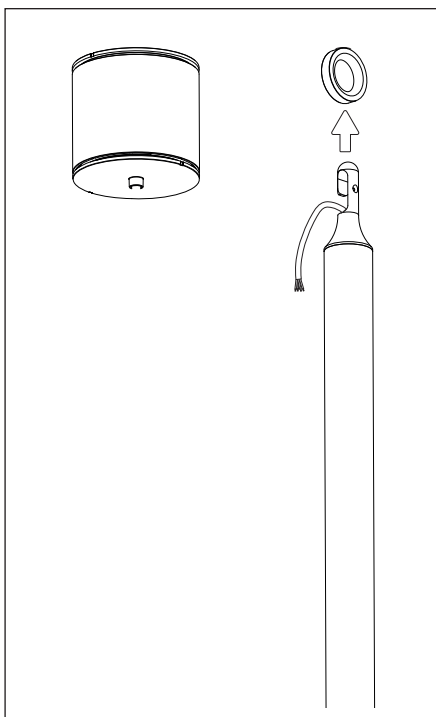
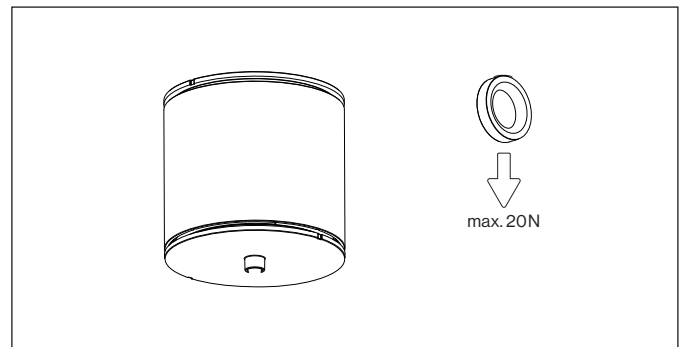
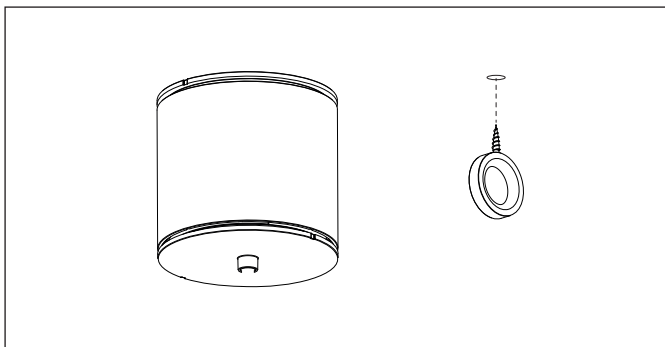
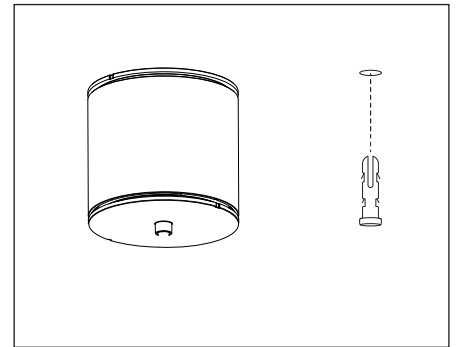
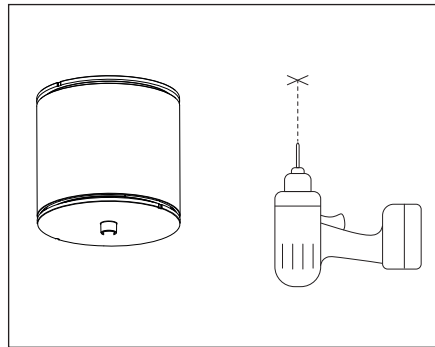
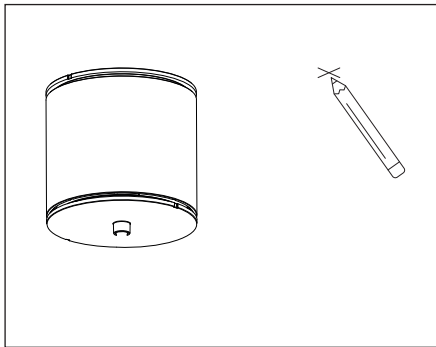

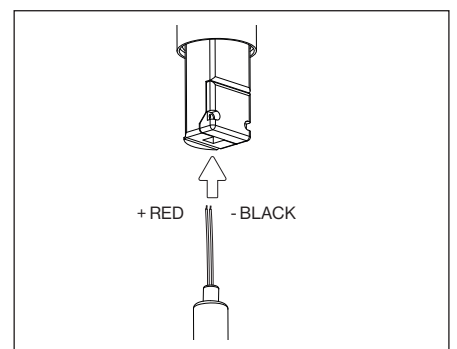
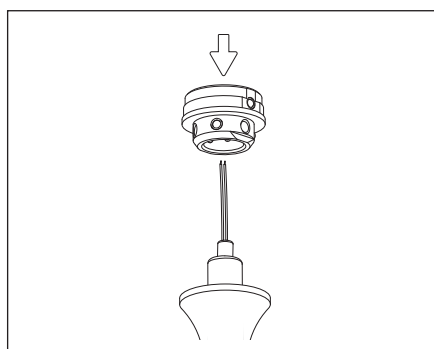
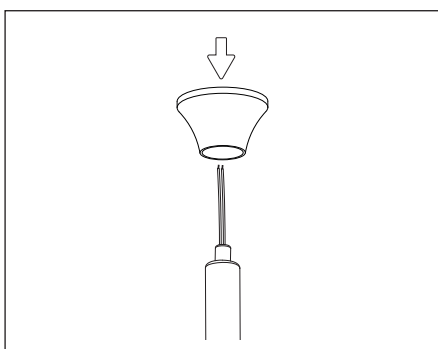
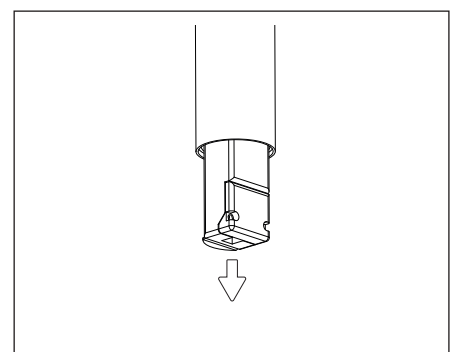
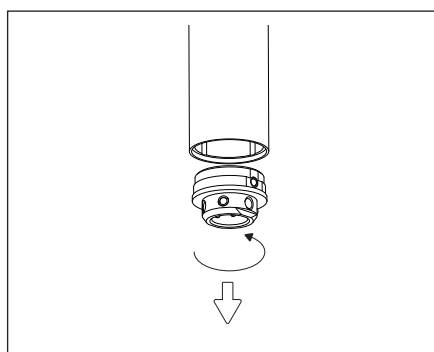
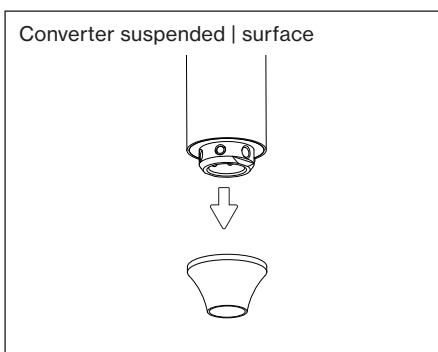
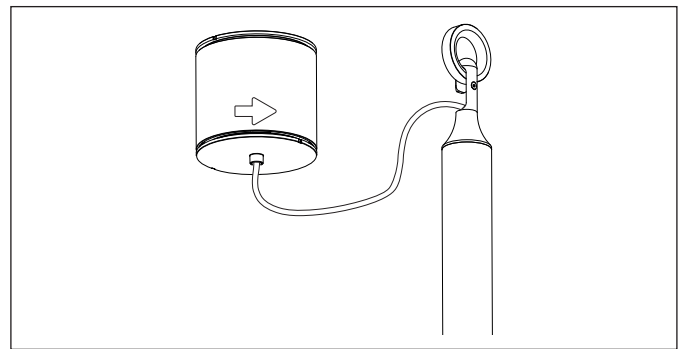
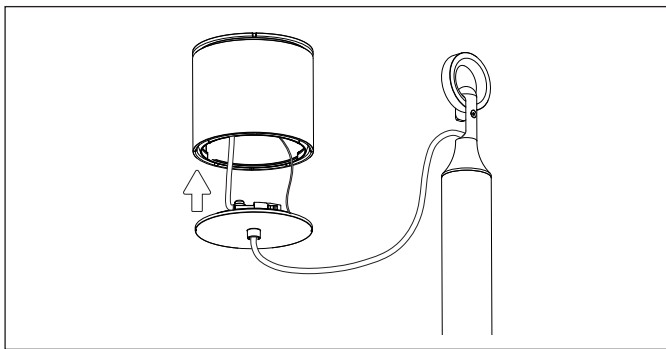
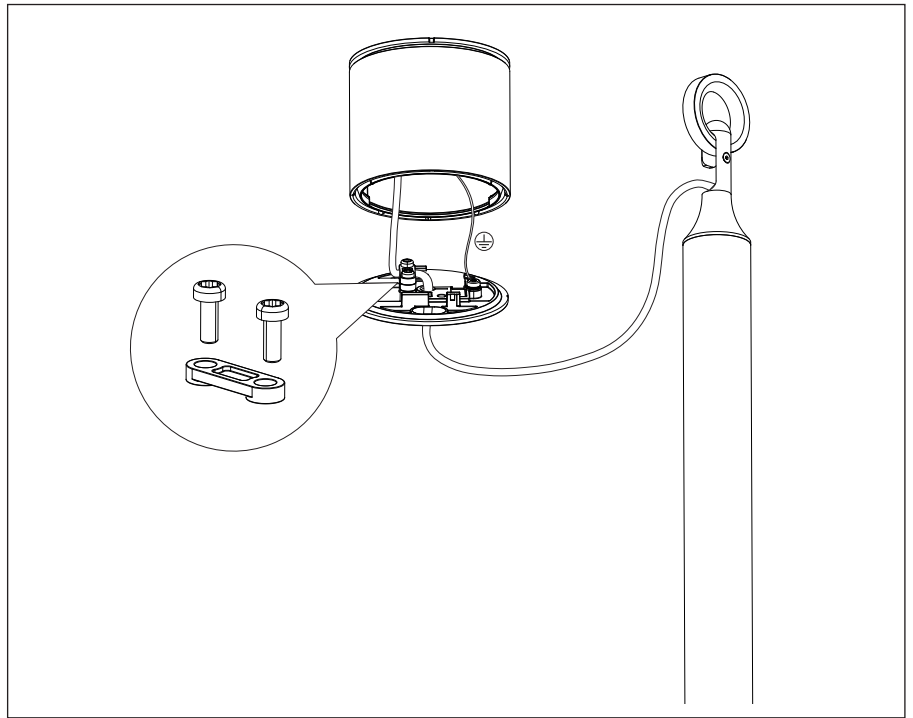
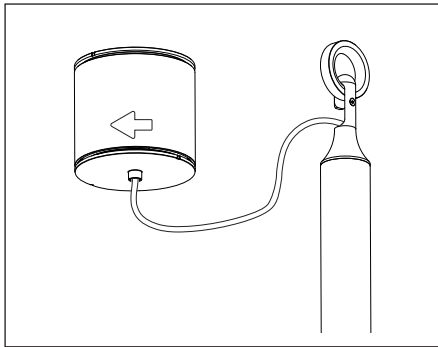
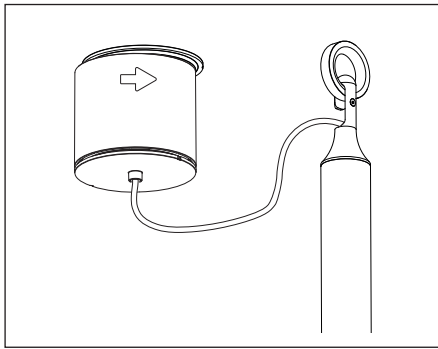

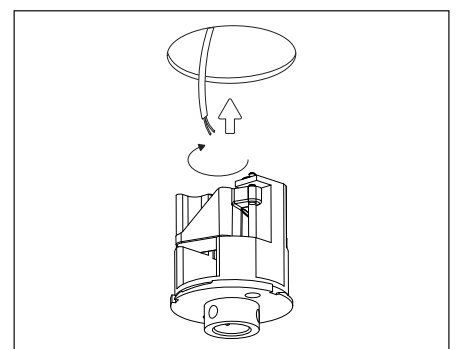
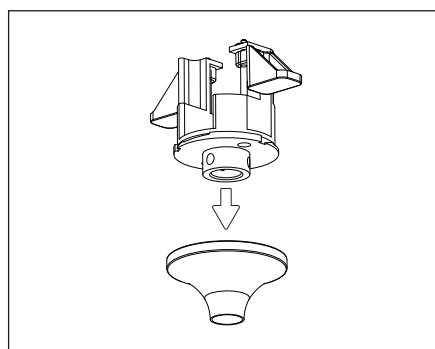
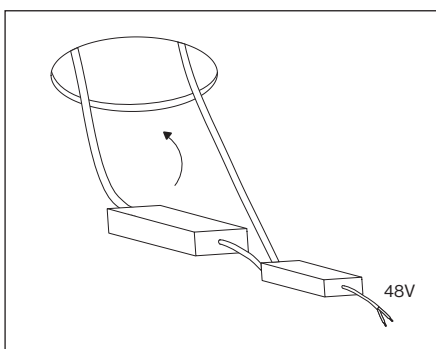
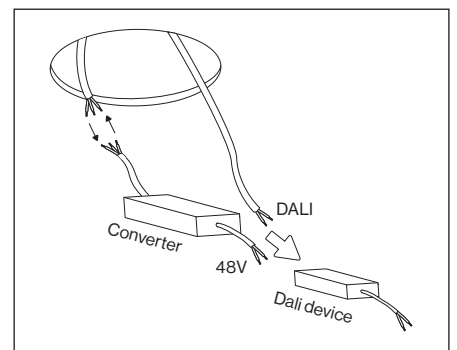
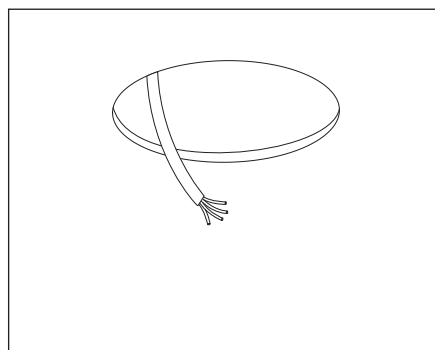
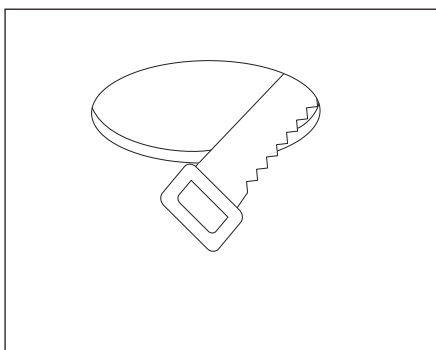
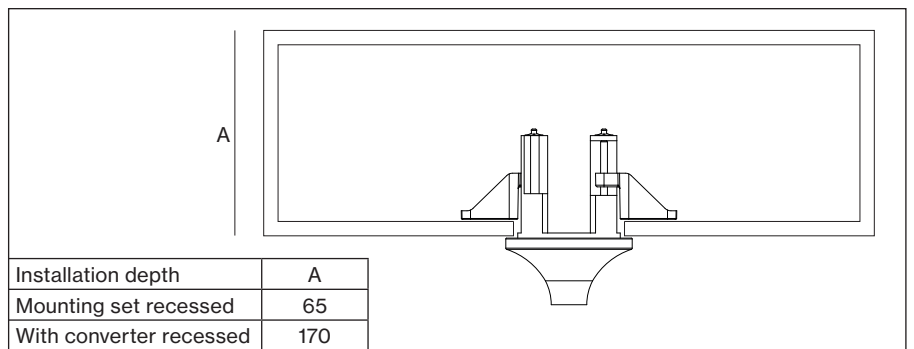
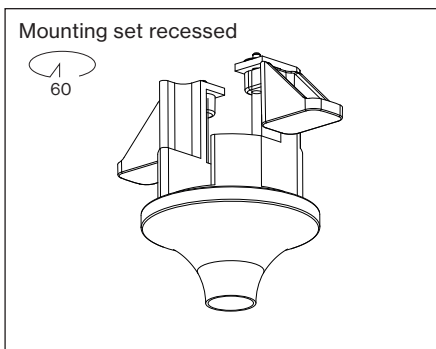
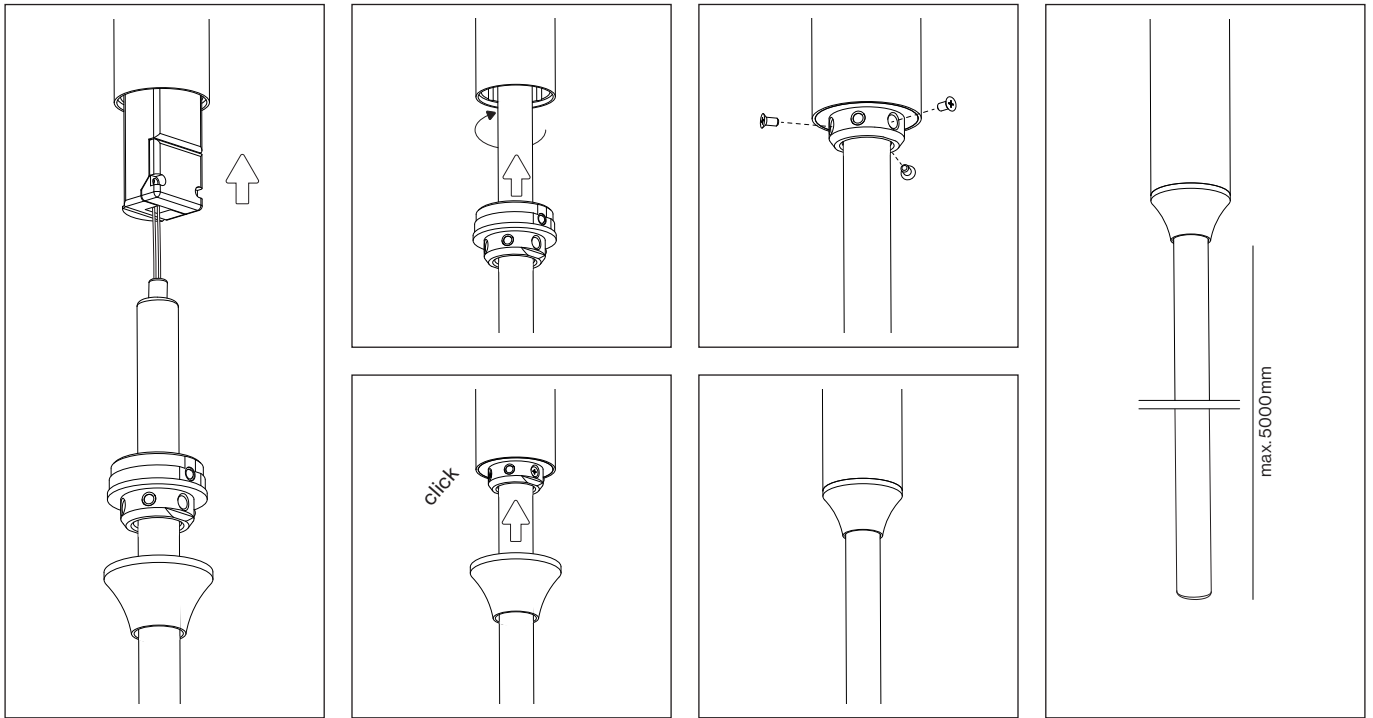

JANE semi-recessed | surface | suspended



Mounting instructions

468202103310

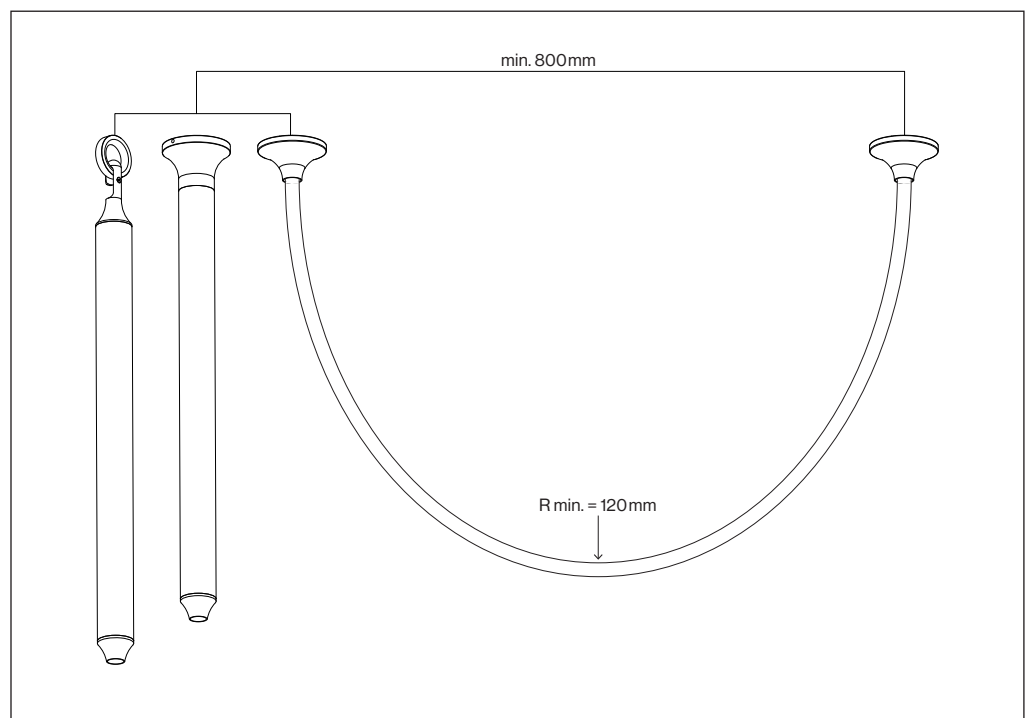
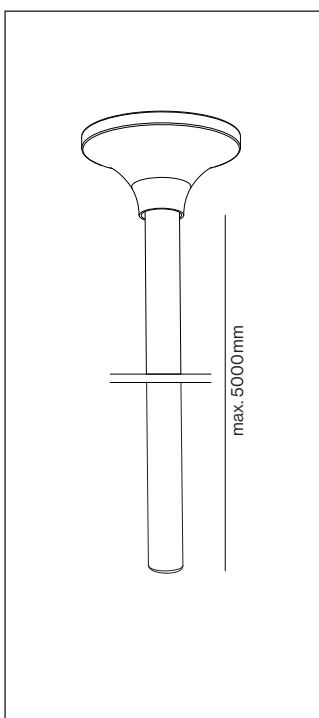
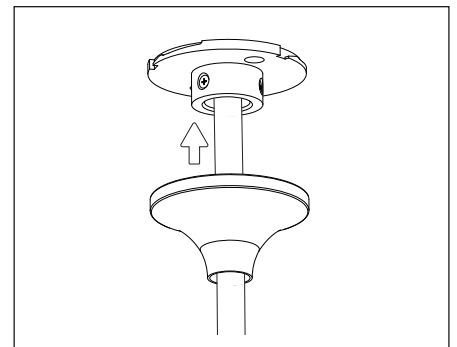
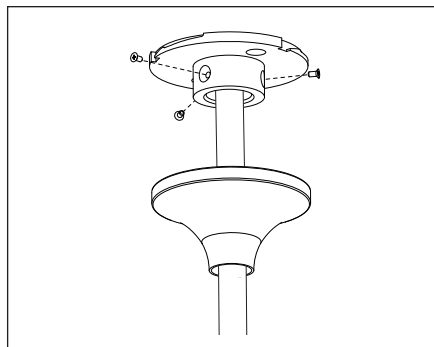
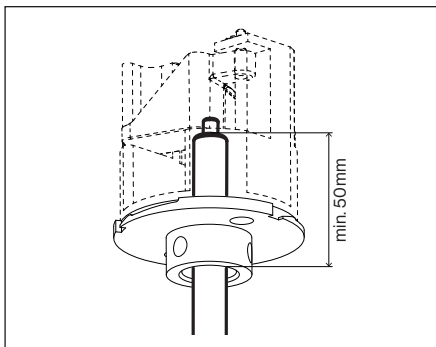
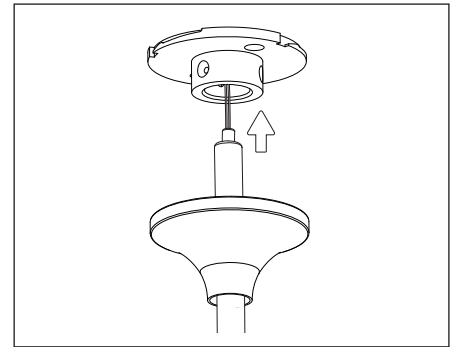
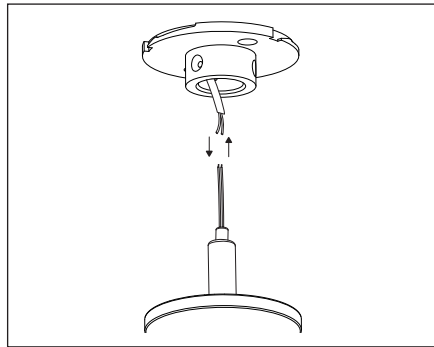
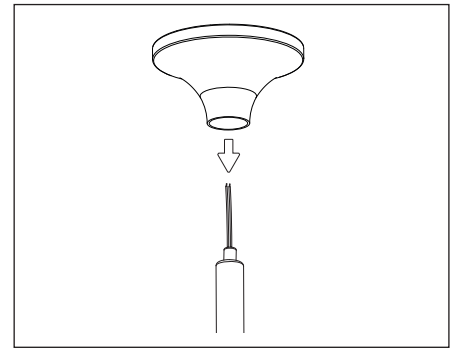
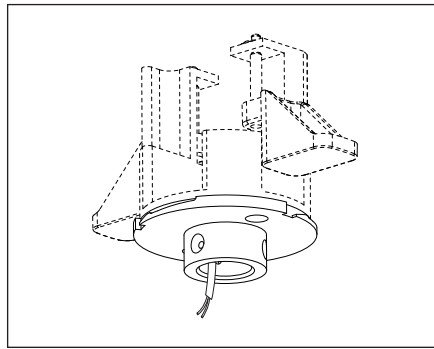
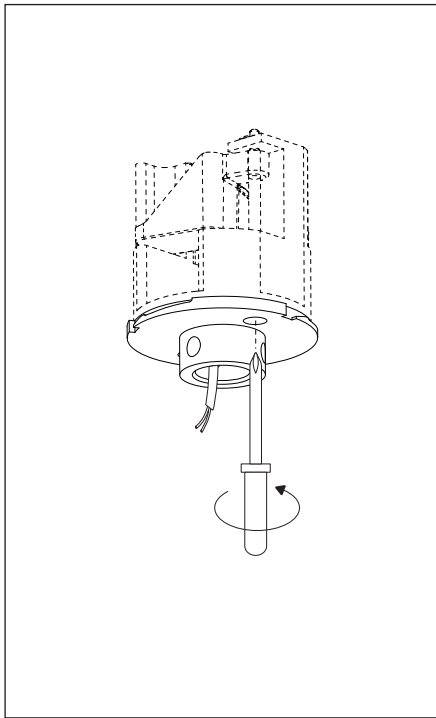

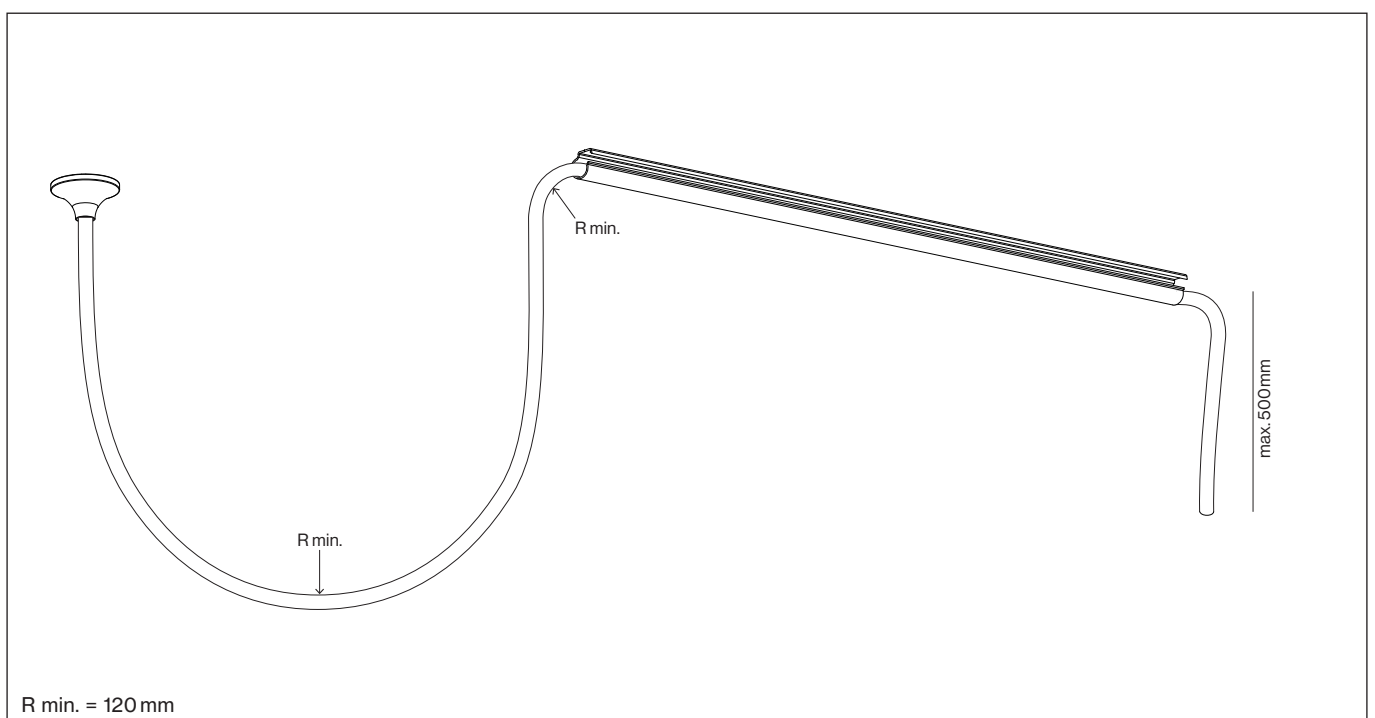
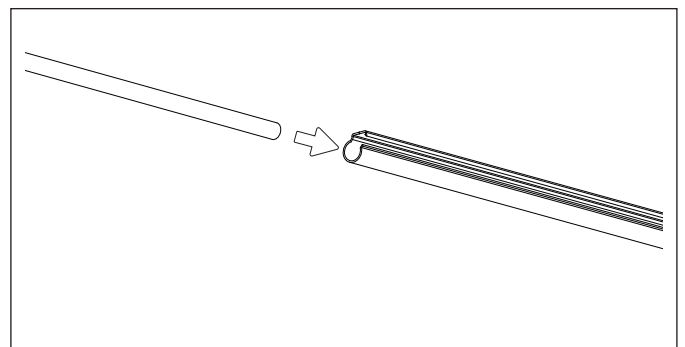
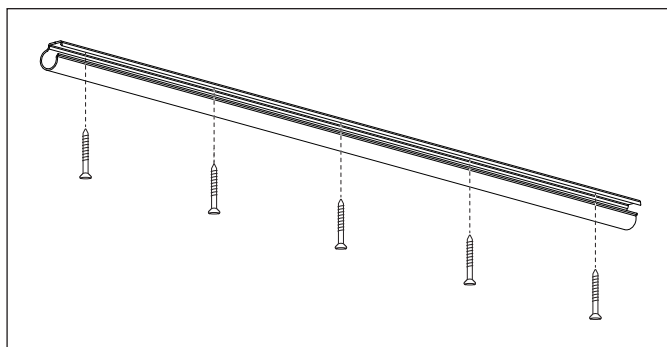
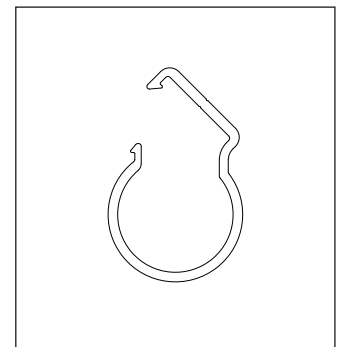
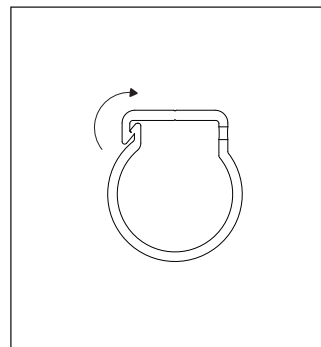
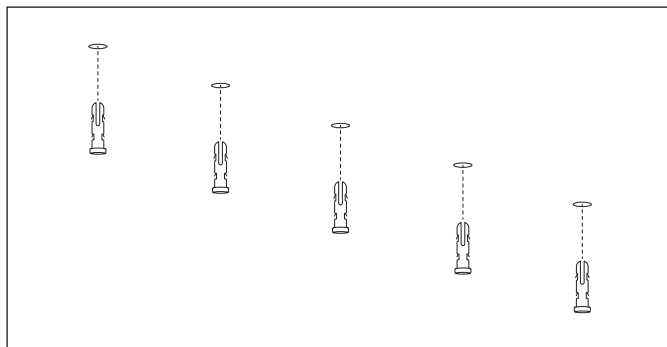
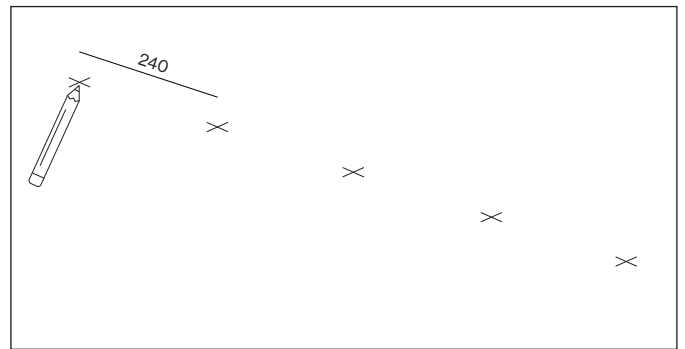
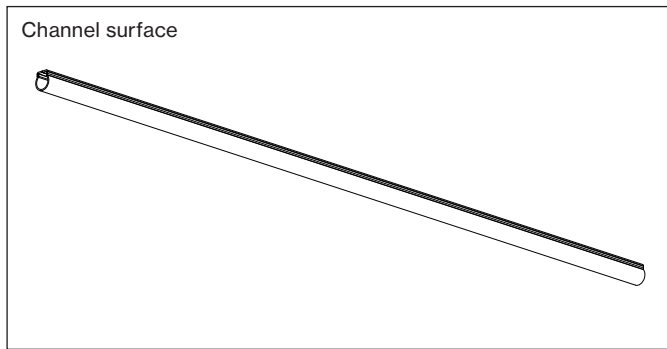

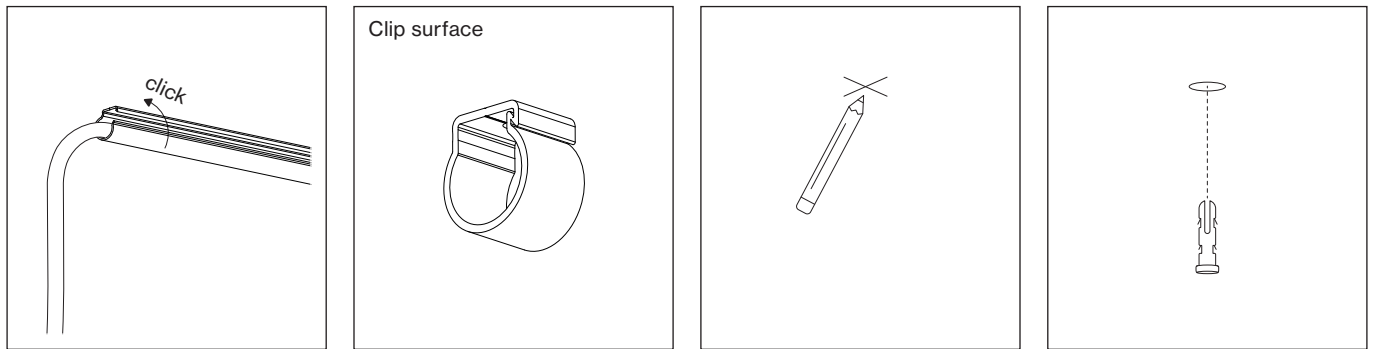

Clip surface

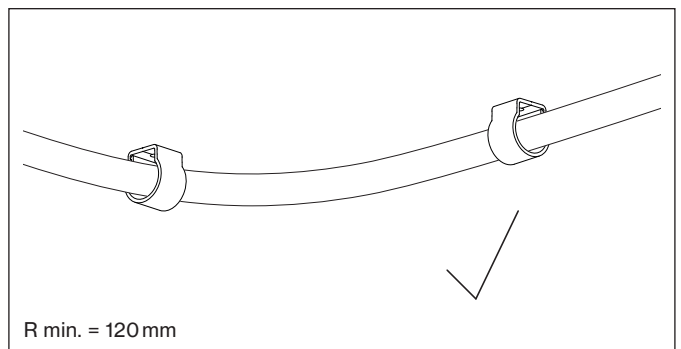
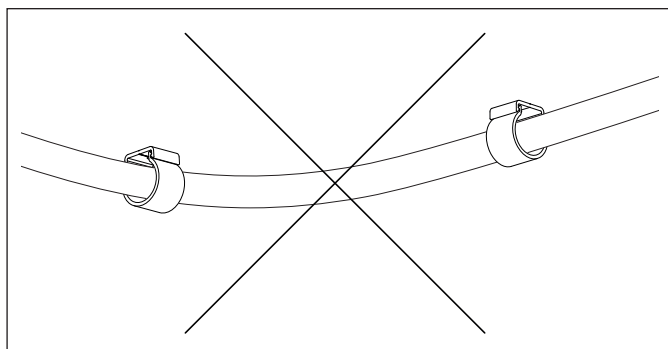
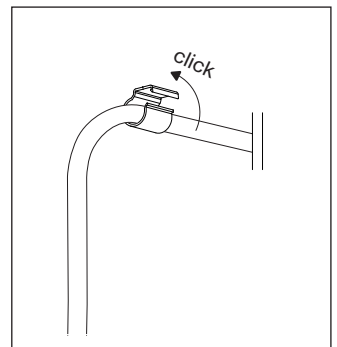
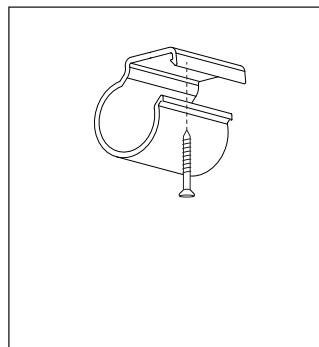
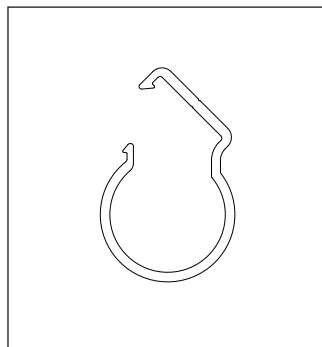
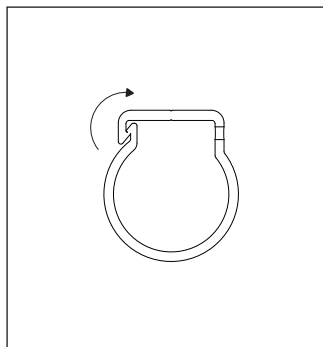
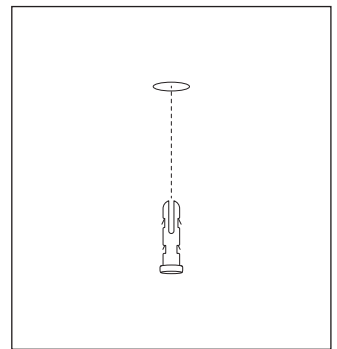
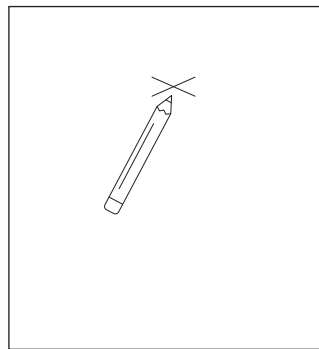
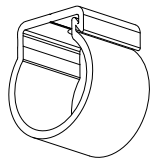

R min. = 120 mm

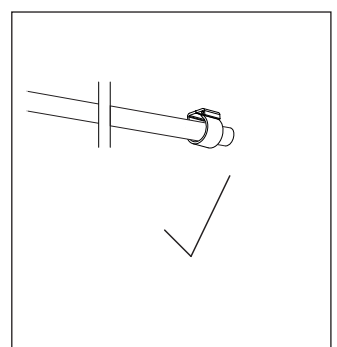
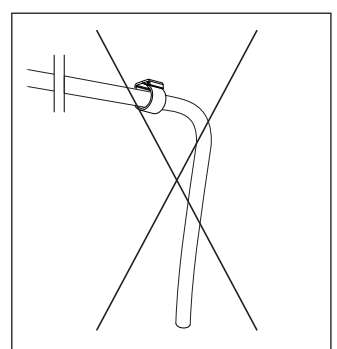
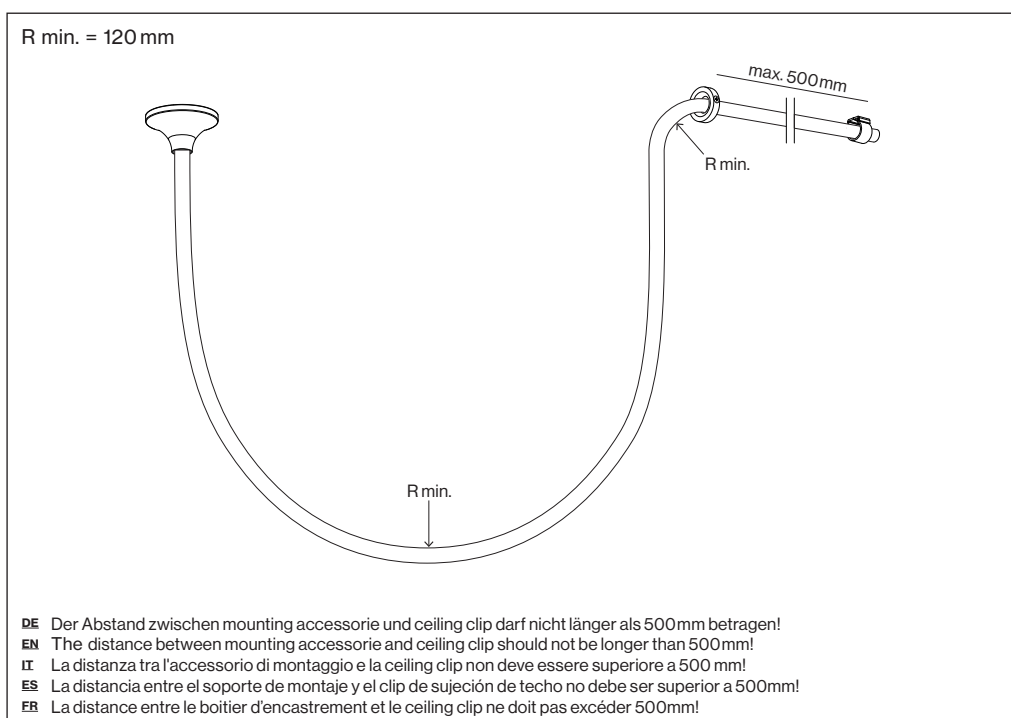

R min. = 120 mm

- DE** Der Abstand zwischen mounting accessorie und ceiling clip darf nicht länger als 500mm betragen!
- EN** The distance between mounting accessorie and ceiling clip should not be longer than 500mm!
- IT** La distanza tra l'accessorio di montaggio e la ceiling clip non deve essere superiore a 500 mm!
- ES** La distancia entre el soporte de montaje y el clip de sujeción de techo no debe ser superior a 500mm!
- FR** La distance entre le boîtier d'encastrement et le ceiling clip ne doit pas excéder 500mm!

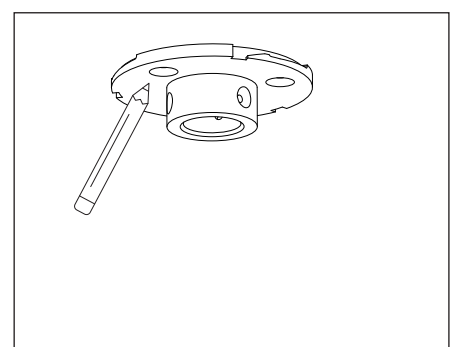
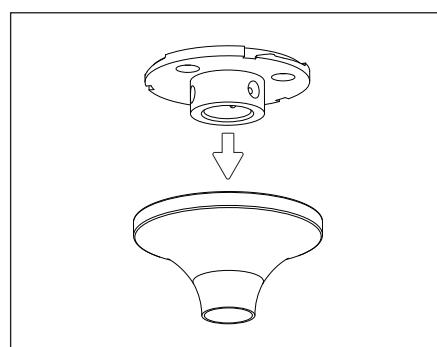
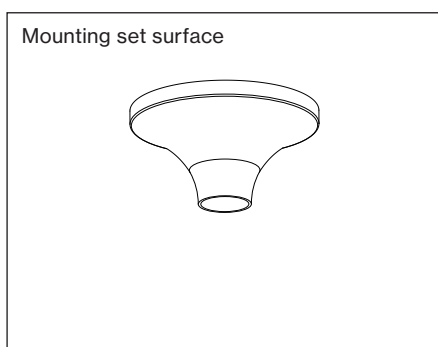
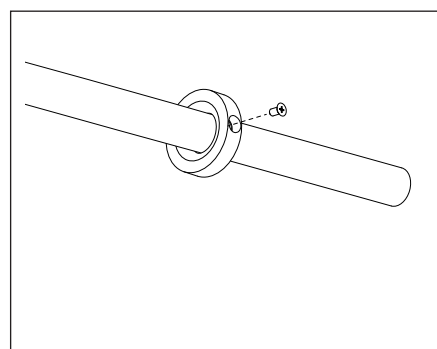
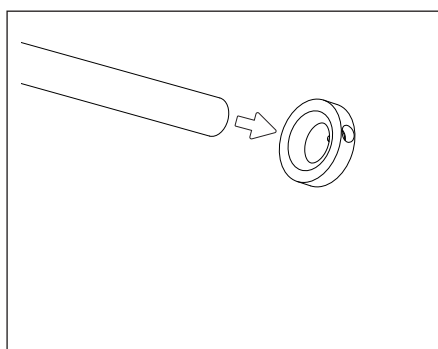
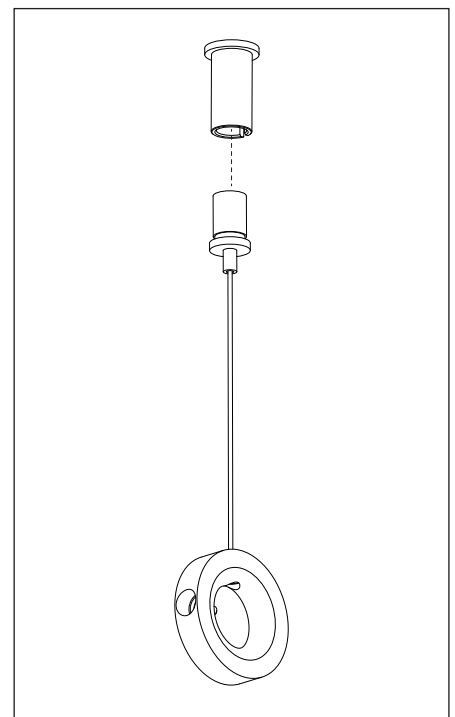
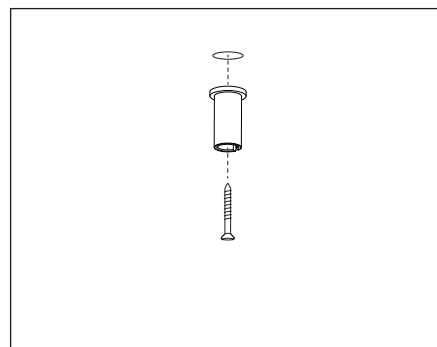
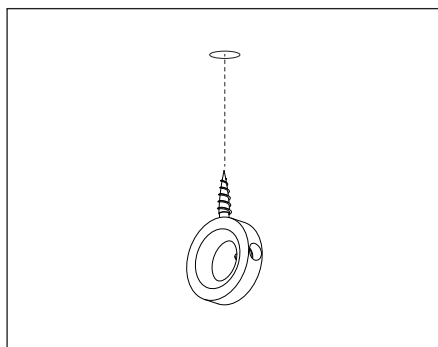
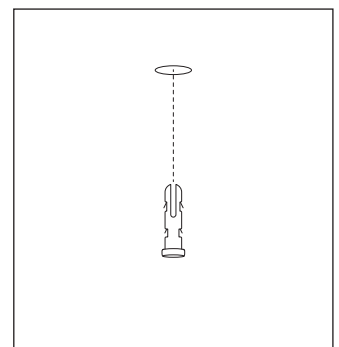
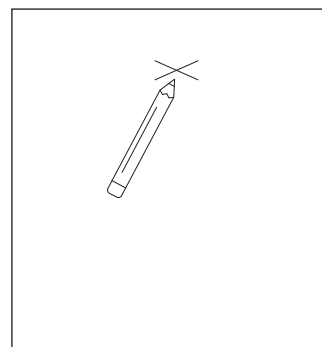
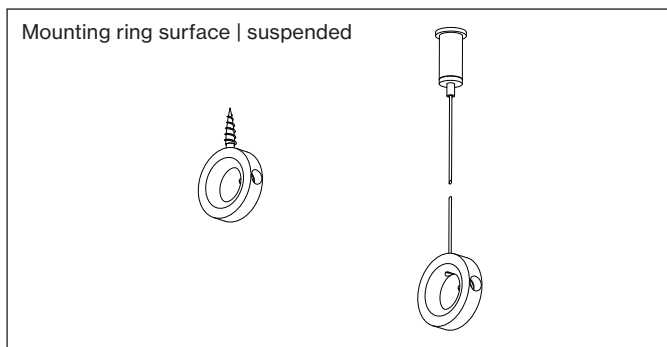
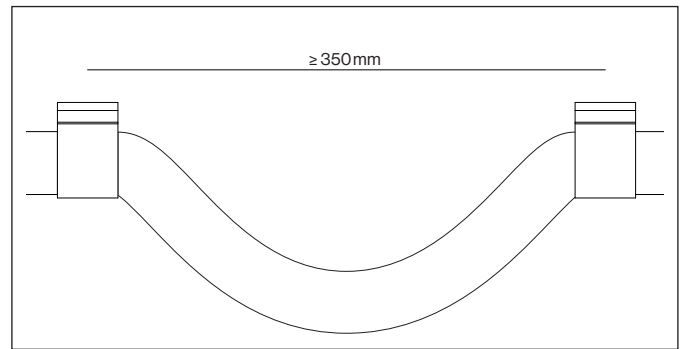
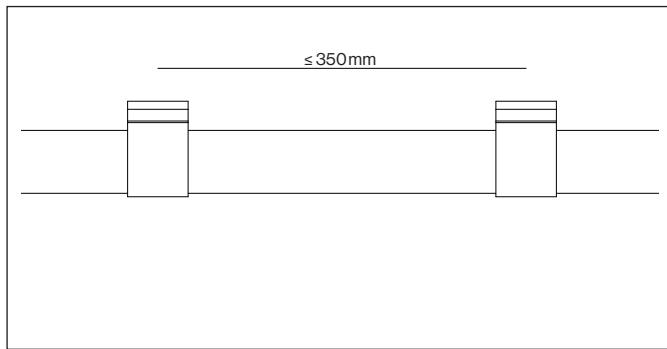

JANE semi-recessed | surface | suspended



Mounting instructions

468202103310

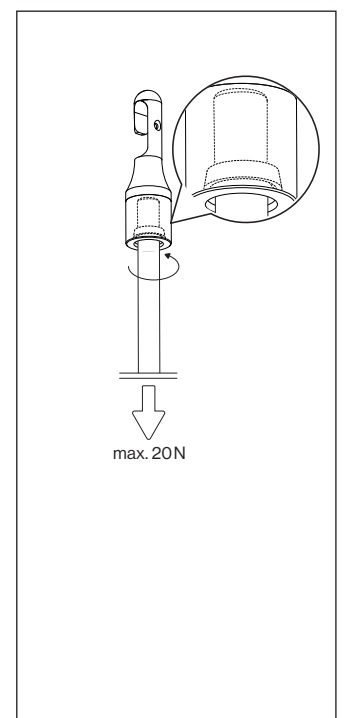
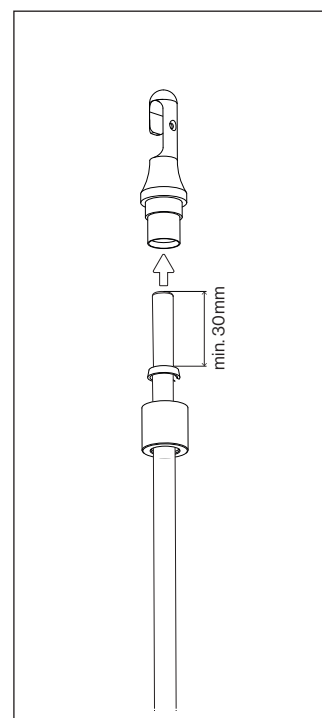
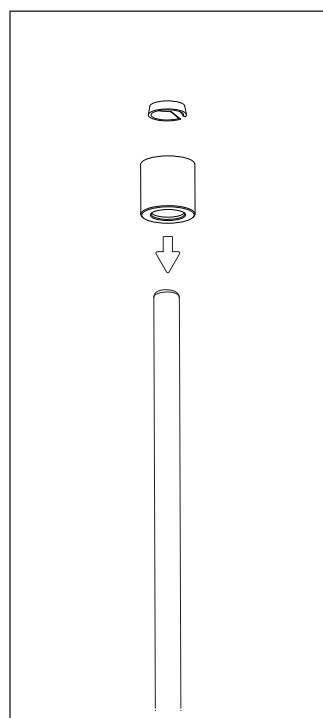
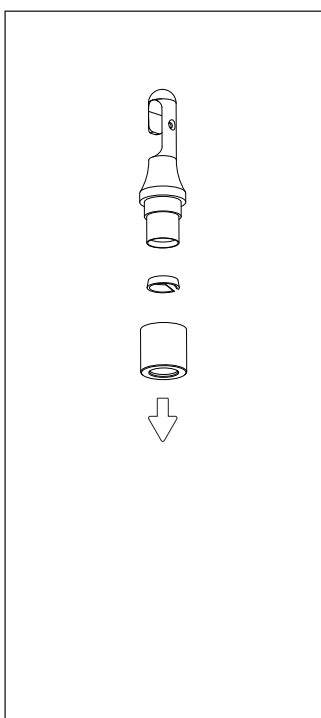
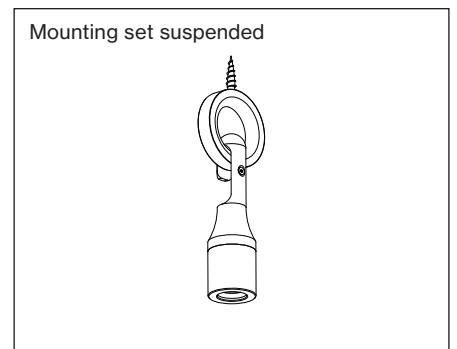
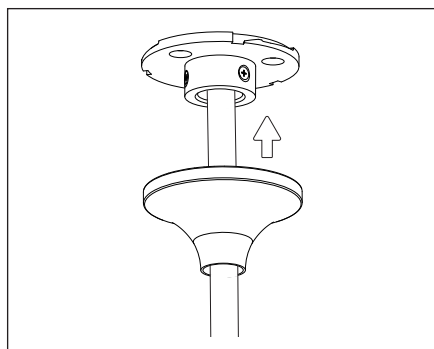
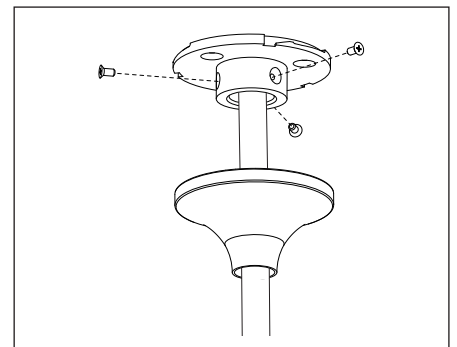
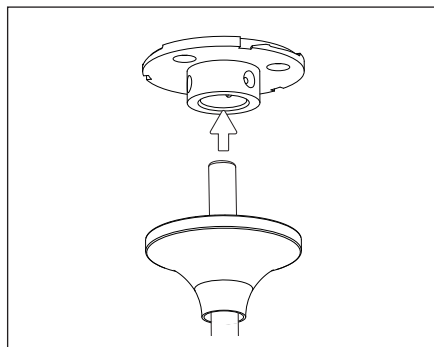
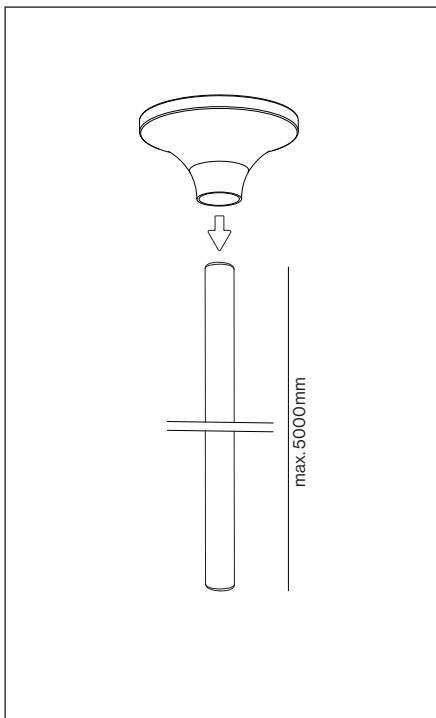
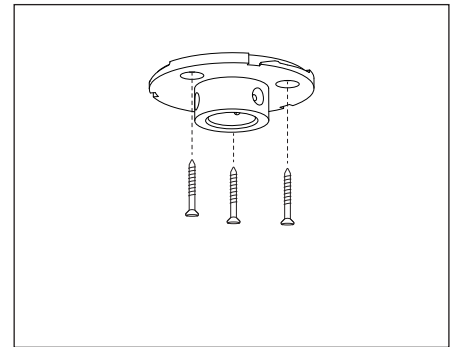
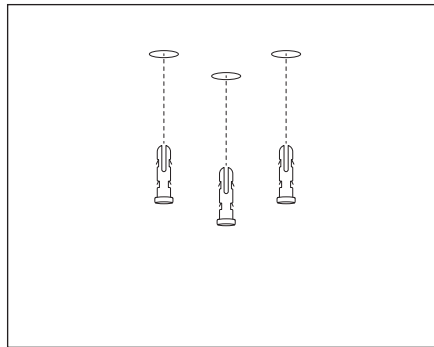
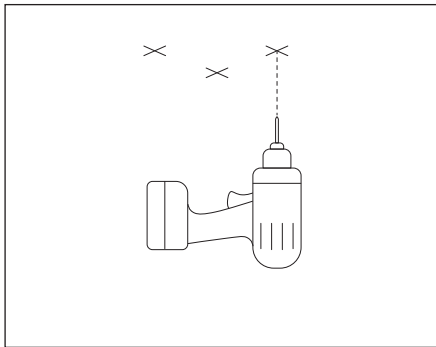

JANE semi-recessed | surface | suspended



Mounting instructions

468202103310

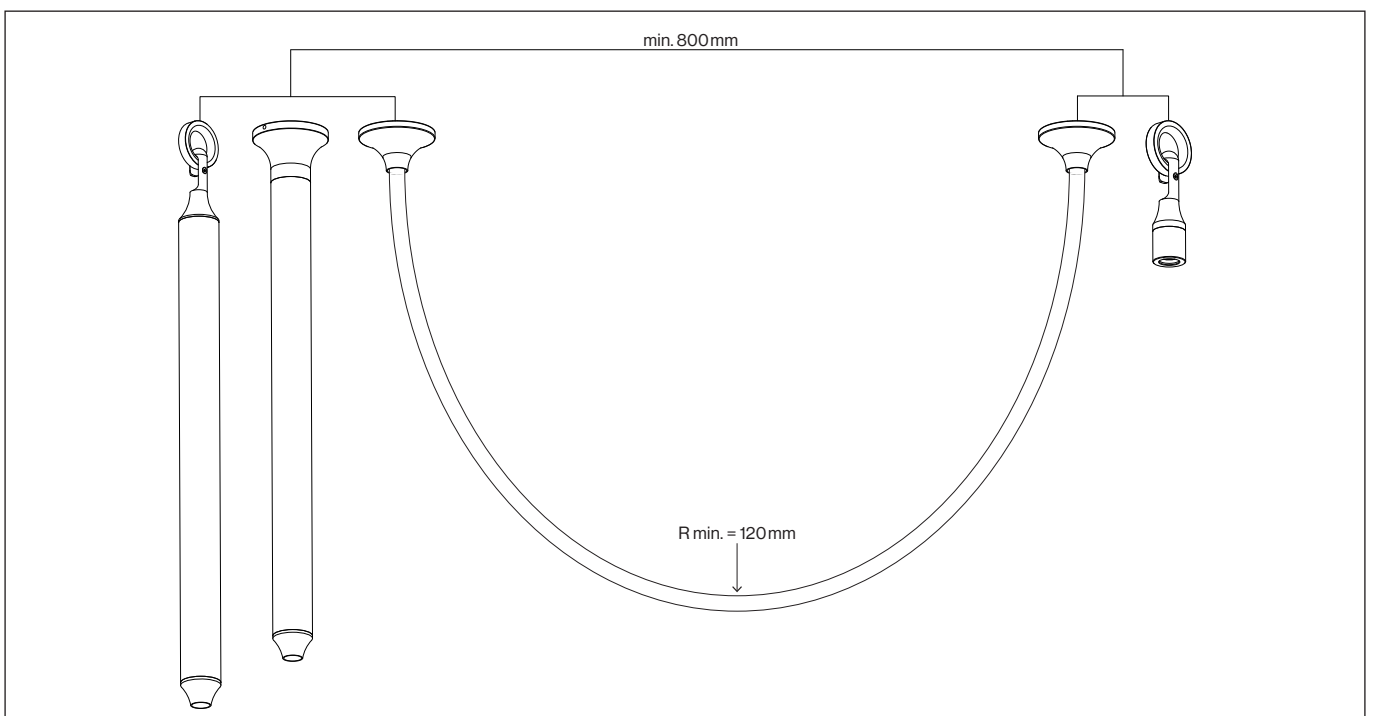
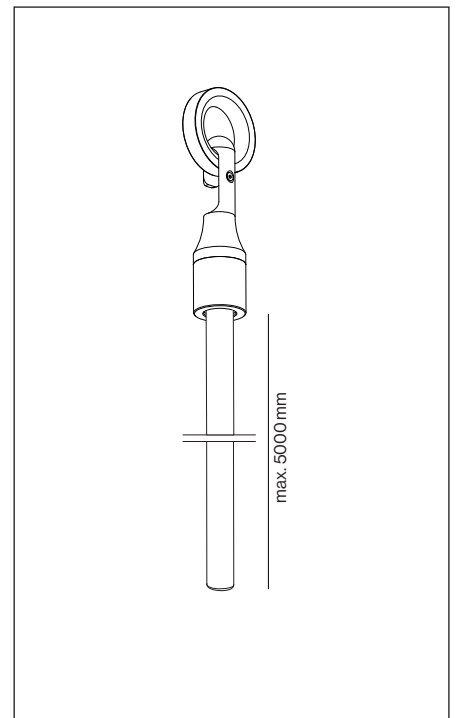
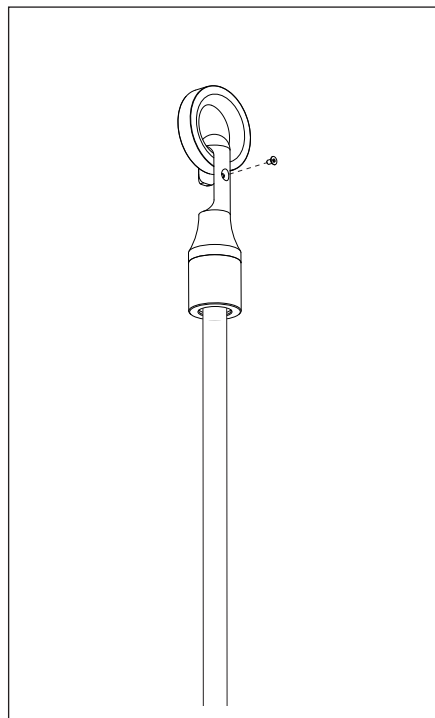
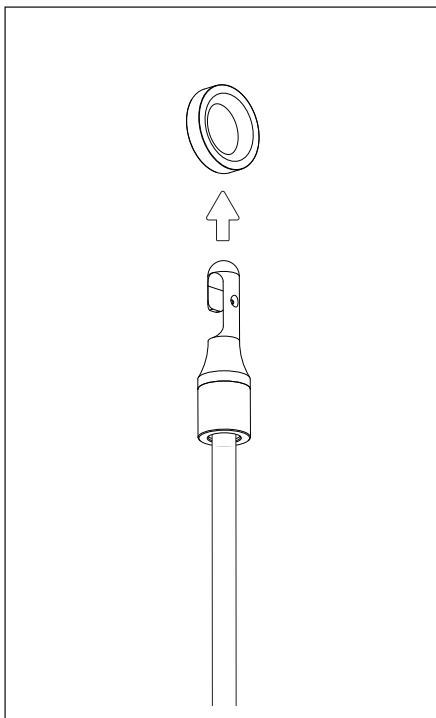
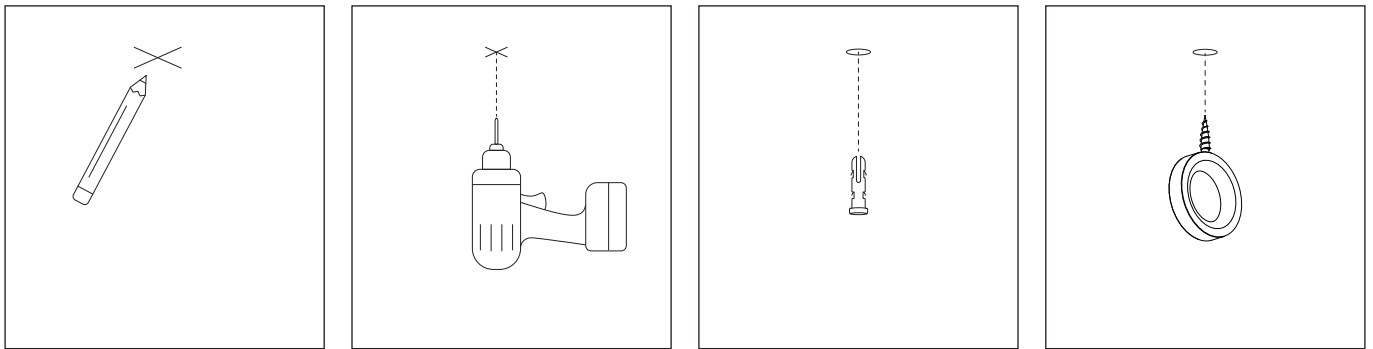

DE Die Demontage erfolgt sinngemäß in umgekehrter Reihenfolge der Montage.

EN The dismounting is proceeded in the reverse order of the mounting.

IT Lo smontaggio si effettua nell'ordine inverso al montaggio.

ES El desmontaje se realiza en el orden inverso al de montaje.

FR Le démontage s'effectue dans l'ordre inverse du montage.

DE Die Abbildungen sind nur symbolische Darstellungen.

EN The illustrations are only symbolic representations.

IT Le illustrazioni sono solo rappresentazioni simboliche.

ES Las ilustraciones son sólo representaciones simbólicas.

FR Les illustrations ne sont que des représentations symboliques.

Cross section 1,5 mm ²									
System power	Feeder cable								System cable length
	≤1m	≤2,5m	≤5m	≤7,5m	≤10m	≤15m	≤20m	≤30m	
25 W	94 m	92 m	90 m	85 m	76 m	67 m	58 m	40 m	
50 W	47 m	45 m	43 m	38 m	29 m	20 m	11 m	-	
75 W	31 m	30 m	27 m	22 m	13 m	4 m	-	-	
100 W	24 m	22 m	19 m	15 m	6 m	-	-	-	
150 W	16 m	14 m	11 m	7 m	-	-	-	-	
200 W	12 m	10 m	7 m	3 m	-	-	-	-	
250 W	9 m	8 m	5 m	-	-	-	-	-	
300 W	8 m	6 m	3 m	-	-	-	-	-	

Cross section 2,5 mm ²									
System power	Feeder cable								System cable length
	≤1m	≤2,5m	≤5m	≤7,5m	≤10m	≤15m	≤20m	≤30m	
25 W	155 m	152 m	148 m	143 m	139 m	130 m	121 m	103 m	
50 W	77 m	74 m	69 m	65 m	60 m	51 m	42 m	24 m	
75 W	50 m	48 m	43 m	39 m	34 m	25 m	16 m	-	
100 W	37 m	35 m	30 m	26 m	21 m	12 m	3 m	-	
150 W	24 m	22 m	17 m	13 m	8 m	-	-	-	
200 W	18 m	15 m	11 m	6 m	2 m	-	-	-	
250 W	14 m	11 m	7 m	2 m	-	-	-	-	
300 W	11 m	9 m	4 m	-	-	-	-	-	

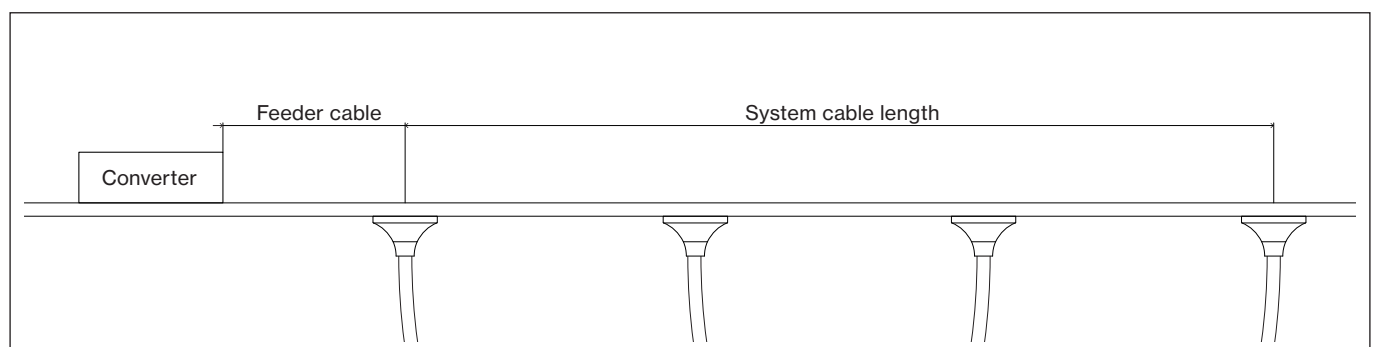

DE Die Montage, Inbetriebnahme und Wartung darf nur von autorisiertem Fachpersonal unter Berücksichtigung dieser Montageanleitung und aller für den jeweiligen Anwendungsbereich geltenden Normen und Vorschriften durchgeführt werden. Stellen Sie die elektrische, mechanische und thermische Eignung der Leuchte für den vorgesehenen Anwendungsbereich sicher und überprüfen Sie nach der Montage die sichere Befestigung der Leuchte. Schalten Sie vor jedem Leuchtmittelwechsel (falls zutreffend) und vor allen sonstigen Arbeiten an der Leuchte (z.B. Reinigung) die Netzspannung ab und warten Sie bis Leuchte und Leuchtmittel vollständig abgekühlt sind. Berücksichtigen Sie die Montagehinweise des Leuchtmittelherstellers beim Einsetzen, Wechseln und Betreiben konventioneller Leuchtmittel. Verwenden Sie für die Reinigung der Leuchte ein weiches, feuchtes Tuch. Für die Reinigung von Kunststoffteilen und Reflektoren können Sie zusätzlich einen handelsüblichen pH-neutralen, alkoholfreien, nicht scheuernden Reiniger verwenden. Bewahren Sie diese Montageanleitung für allfällige Wartungsarbeiten gut auf. Bei nachträglichen Änderungen an der Leuchte wird keine Haftung übernommen. Ersetzen Sie unverzüglich beschädigte Schutzgläser bzw. Schutzabdeckungen. Die Einbauprofile sollten nur von geschultem Fachpersonal (Trockenbaufirma) eingebaut werden. Chemikalien die korrodierende Wirkungen haben, dürfen auf die Leuchte nicht einwirken. Die Leuchte muss regelmäßig gereinigt werden, um Fremdstablagungen zu vermeiden, dazu darf kein Hochdruckreiniger verwendet werden, beim Reinigen darf die Leuchte nicht mit Metall angreifenden Reinigungsmitteln in Berührung kommen. LEDs sind hochwertige elektronische Bauteile! Bitte vermeiden Sie während der Montage oder Wartungsarbeiten eine direkte Berührung der LED-Lichtaustrittsfläche mit den Händen. Um Beschädigungen des Profils zu vermeiden, müssen Unebenheiten der Wand bzw. Decke vor der Montage der Profile ausgeglichen werden. Der LED-Stromkreis muss immer geschlossen sein, bevor der Konverter an das Netz angeschlossen wird. XAL übernimmt keine Haftung für Schäden bei Nichtbeachtung dieser Vorschrift. Um die einwandfreie Funktion der Profile zu gewährleisten, dürfen die Profile bei der Montage nicht deformiert werden. Die vor Ort verwendeten Betriebsgeräte und/oder LED-Konverter müssen der EN/IEC 61347-2-13 entsprechen und von einem akkreditierten Labor geprüft sein. Die Leistung und der Lichtstrom unterliegen initial einer Toleranz +/- 10%. Toleranz der Farbtemperatur +/- 150 Kelvin. Es dürfen keine systemfremden Gegenstände über das System gehängt werden (wie z.B. Dekomaterial u. dgl.), die das System in Bezug auf statische, elektrische, mechanische und thermische Beeinträchtigung belasten und somit Personen gefährden oder anderwärtig Schaden verursachen könnten.

Die Leuchte ist nicht für den Außenbereich geeignet.
Die eingebaute Lichtquelle ist nicht tauschbar. Bei einem notwendigen Tausch (z.B. am Ende der Lebensdauer) muss die Leuchte an den Erzeuger retourniert werden.
Der Lichtschlauch darf nicht an die Netzversorgung angeschlossen werden, wenn er noch in der Verpackung oder auf eine Spule gerollt ist.
Den Lichtschlauch nicht verwenden, wenn er abgedeckt ist oder in einer Oberfläche eingelassen ist.
Den Lichtschlauch nicht öffnen oder aufschneiden/aufschlitzen.

EN Installation, commissioning and maintenance may only be performed by authorized and qualified personnel, taking into consideration these installation instructions and any standards and regulations applicable to the respective area of application. The electrical, mechanical and thermal suitability of the luminaire for the intended area of application must be ensured and the secure fastening of the luminaire after its installation must be controlled. Turn off supply voltage before replacing any lamps (if applicable) as well as before performing any other works on the luminaire (e.g. cleaning) and wait until luminaire and lamp have completely cooled off. Please refer to the installation notes of the lamp manufacturer when inserting, replacing and operating conventional lamps. Use a soft, damp cloth to clean the luminaire. To clean plastic components and reflectors, a standard pH neutral, alcohol-free, non-abrasive cleaning agent may also be used. Keep these installation instructions in a safe place as reference for any future maintenance works. No liability is accepted for any subsequent change of the luminaire. The lamp may only be used with a safety guard. Damaged protection glasses and covers have to be replaced immediately. The recessed profiles should only be installed by instructed professionals (for plasterboard works). Corrosive chemical products must not be used as this may have a detrimental effect on the luminaire. Regularly clean the luminaire in order to avoid the buildup of extraneous rust deposits and do not use any high pressure cleaner. When cleaning, the luminaire must not come into contact with acid cleaning agents. LEDs are high-quality electronic components! Please avoid touching by hand the LED light emitting surface while assembling or replacing parts and during maintenance work. To avoid damage of the profile, unevenness on the wall or ceiling must be leveled out before assembling the profiles. While assembling the profiles, make sure they do not deform in order to guarantee their proper function. The LED circuit must always be closed, before the converter is connected to the main power. XAL does not assume any liability for damages resulting from nonobservance of this rule. The ballasts and/or LED-driver which are used should pass the EN/IEC 61347-2-13 and must be approved from an authorized test house. Luminous flux and connected electrical load are subject to an initial tolerance of up to +/- 10%. Color temperature is subject to a tolerance of up to +/- 150 Kelvin from the nominal value. No objects that do not belong to the lighting system (such as decorative parts, etc.) must be hung over the system so that the system will not be subject to static, electrical, mechanical, or thermal stress, no persons will be put at risk and no other damage will be caused.

The lamp is not suitable for outdoor use.
The light source of this luminaire is not replaceable. In case the light source need to be replaced (e.g. at the end of its life), the whole luminaire shall be replaced.
Do not connect the rope light to the mains supply if it is still in its packaging or rolled onto a spool.
Do not use the light tube if it is covered or embedded in a surface.
Do not open or cut/slit the light tube.

IT Il montaggio, la messa in funzione e la manutenzione possono essere effettuati solo da tecnici autorizzati, nel rispetto delle presenti istruzioni di montaggio e di tutte le norme e disposizioni vigenti per il relativo campo di applicazione. Assicurarsi dell'idoneità elettrica, meccanica e termica della lampada per il campo di applicazione previsto e verificare dopo il montaggio che la lampada sia fissata saldamente. Prima di ogni sostituzione della lampada (se applicabile) e prima di ogni intervento sulla lampada (ad esempio pulizia) staccare la tensione di rete e aspettare fino al completo raffreddamento della lampada e della lampadina. Rispettare le istruzioni di montaggio del relativo produttore per l'impiego, la sostituzione e l'azionamento della lampadina convenzionale. Per la pulizia della lampada utilizzare un panno morbido e umido. Per la pulizia delle parti in plastica e dei riflettori si può utilizzare inoltre un detergente normale a pH neutro, senza alcool, non abrasivo. Conservare le presenti istruzioni di montaggio in buone condizioni per eventuali interventi di manutenzione. Si declina qualsiasi responsabilità per modifiche successive alla lampada. La lampada può essere fatta funzionare solamente con un dispositivo di protezione. Vetri e coperchi di sicurezza danneggiati devono essere sostituiti immediatamente. I profili da incasso dovrebbero essere montati solo da personale specializzato (ai soffitti in cartongesso). La lampada deve essere pulita regolarmente per evitare il deposito di ruggine da sorgenti esterne e non si deve utilizzare alcun pulitore ad alta pressione. Per la pulizia, evitare che la lampada entri in contatto con detersivi che corrodono il metallo. I LED sono componenti elettronici di elevata qualità! Evitare per favore durante il montaggio, la sostituzione e lavori di manutenzione il contatto diretto con le mani della superficie di uscita della luce LED. Per evitare danni al profilo, le irregolarità sulla parete e sul soffitto devono essere eliminate prima di procedere al montaggio dei profili. Per garantire il perfetto funzionamento, fare attenzione a non deformare i profili durante il montaggio. L'apparecchio luminoso deve essere montato in tale modo, che da una distanza di meno di xm lo sguardo permanente nell'apparecchio luminoso non è possibile. Il circuito LED deve sempre essere chiuso prima che il convertitore venga allegato alla spina. XAL non si prende la responsabilità per eventuali danni se questa regola non viene rispettata. I reattori e/o converter LED usati devono essere standardizzati adeguatamente EN/IEC 61347-2-13 e devono essere approvati da un laboratorio autorizzato. I dati di flusso luminoso e potenza sono inizialmente passibili di tolleranze di +/- 10%. Tolleranza della temperatura di colore: +/- 150 Kelvin. Non appendere in nessun caso oggetti senza riferimento al sistema (come decorazioni o simili) che possano in qualche modo pregiudicarne la stabilità statica, elettrica, meccanica o termica, mettendo così in pericolo l'incolumità di cose o persone. I prodotti chimici che hanno un effetto corrosivo non devono assolutamente entrare in contatto con la lampada













La lampada non è adatta per uso esterno.
Non si può sostituire la sorgente luminosa di questo apparecchio; nel caso la sorgente luminosa deve essere sostituita (per esempio è guasta), l'apparecchio dovrebbe essere sostituito completamente.
La luce a fume non deve essere collegata alla rete elettrica se è ancora nel suo imballaggio o arrotolata su una bobina.
Non usare la luce a corda se è coperta o incastrata in una superficie.
Non aprire o tagliare la luce della fume.

ES La instalación, la puesta en marcha y el mantenimiento sólo deben realizarse por personal especializado considerando esta guía de instalación y todas las normas y reglamentaciones vigentes. Asegurarse de la aptitud eléctrica, mecánica y térmica de la luminaria para la aplicación prevista y comprobar la fijación segura de la luminaria después de su instalación. Apagar siempre la corriente antes de cambiar la lámpara (en caso justificado) o de realizar algún otro trabajo en esta (p.ej. Limpieza). Esperar hasta que se enfríen la luminaria y la lámpara completamente. Tener en cuenta las instrucciones de montaje del fabricante al colocar, cambiar y utilizar lámparas convencionales. Para la limpieza de la luminaria utilizar un paño suave y húmedo. Para limpiar componentes de plástico y reflectores puede usar también un limpiador pH neutral y sin alcohol que no roce el material. Guardar esta guía de instalación para trabajos de mantenimiento. Para modificaciones futuras en la luminaria no se asume ninguna responsabilidad. Para modificaciones futuras en la luminaria no se asume ninguna responsabilidad. La luminaria sólo debe accionar con un dispositivo de seguridad. Cambie de inmediato los vidrios y las tapas de protección dañados. Los perfiles para empotrar deben ser instalados por personal especializado. Químicos que tienen efectos corrosivos no deben influir en la luminaria. La luminaria debe ser regularmente limpiada para evitar asentamientos de oxidaciones ajenas, para esto no se debe utilizar ningún limpiador de alta presión. En el momento de la limpieza la luminaria no debe entrar en contacto con productos de limpieza que afecten al metal. Los LED son componentes electrónicos de alta calidad! Por favor durante el montaje o el mantenimiento evite el contacto directo con la superficie de emisión. Para evitar daños en el perfil, los desniveles de las paredes y techos deben ser enrasados antes del montaje de los perfiles. Para garantizar su buen funcionamiento, los perfiles no deben sufrir deformaciones durante el montaje. El circuito LED debe ser cerrado antes de conectar el convertidor. XAL no asume garantía si esta norma no se respeta. Los balastos y/o convertidores LED utilizados deben ser estandarizados conforme a las normas EN/IEC 61347-2-13 y deben ser aprobados por un laboratorio autorizado. Los datos aportados en relación al luminario y el consumo están sujetos a una tolerancia de +/- 10% Tolerancia referente a la temperatura de color +/- 150 Kelvin. Sobre el sistema no se deben colgar objetos ajenos al sistema (p.ej. materiales de decoración o similares) que sobrecarguen al sistema en relación al impacto estático, mecánico y térmico y por consiguiente pongan en peligro a personas o puedan causar daños de otro tipo.

La luminaria no es apta para utilizarla en el exterior.
La fuente luminosa de esta luminaria no se puede reemplazar, en caso de que la fuente luminosa deba ser reemplazada (p. ej. al final de su vida útil), toda la luminaria deberá ser sustituida.
La lámpara de cuerda no debe conectarse a la red eléctrica si todavía está en su embalaje o enrollada en una bobina.
No utilice la luz de cuerda si está cubierta o incrustada en una superficie.
No abra ni corte la luz de la cuerda.

FR Le montage peut être effectué seulement par des spécialistes respectant les normes et réglementations en vigueur. Assurez-vous de l'aptitude thermique, mécanique et électrique du luminaire pour le domaine d'utilisation prévu et vérifiez le montage correct du luminaire après l'installation. Coupez la tension avant de changer les lampes ou avant de réaliser des travaux sur le luminaire (p.ex. nettoyage). Attendez jusqu'à ce que le luminaire et les lampes soient complètement refroidis. Respectez les indications de montage du fabricant quand vous changez, installez et utilisez les sources lumineuses. Utilisez un chiffon doux et humide pour nettoyer le luminaire. Pour le nettoyage des pièces en plastique et des réflecteurs vous pouvez, en outre, utiliser un nettoyant PH neutre, sans alcool et non abrasif, disponible dans le commerce. Conservez bien cette notice de montage pour tout travail de maintenance. Le luminaire ne convient pas pour une utilisation extérieure. Nous déclinons toute responsabilité en cas de modifications ultérieures. Les LED sont des composants électroniques de haute qualité! Évitez de toucher la surface émettrice de lumière LED avec les mains lors du montage ou du remplacement. Pour éviter l'endommagement du profil, il est nécessaire de compenser les irrégularités du mur ou du plafond avant le montage des profils. Afin de garantir un fonctionnement irréprochable des profils, ceux-ci ne doivent pas être déformés lors du montage. Il faut que le circuit de LED soit fermé avant de connecter le convertisseur. XAL ne assume pas la garantie si cette norme ne se respecte pas. Le ballast utilisé et/ou convertisseur LED doit répondre au norme EN/IEC 61347-2-13 et doit être approuvé par un autorité compétente. La puissance et le flux lumineux affichent d'origine une tolérance de +/-10%. Tolérance de la couleur de température: +/- 150 Kelvin. Il est interdit de placer des objets n'appartenant pas au système (p.ex. des décorations etc.) sur le système qui modifient les qualités statiques, électriques, mécaniques et thermiques de l'appareil puisqu'ils peuvent mettre en danger les personnes ou provoquer d'autres dommages. Les profils encastrés doivent être installés par spécialistes.

La luminaria n'est pas apte pour l'utilisation extérieure.
La source de ce luminaire n'est pas remplaçable, en fin de vie le luminaire complet doit être remplacé.
Le cordon lumineux ne doit pas être raccordé au réseau électrique s'il est encore dans son emballage ou enroulé sur une bobine.
N'utilisez pas le cordon lumineux s'il est couvert ou encastré dans une surface.
Ne pas ouvrir ou couper/fendre le cordon lumineux.

 220-240V	<p>DE Schutzklasse I. Leuchten mit Schutzleiteranschluss. EN Protection class I. Luminaires with protective earth connection. IT Classe isolamento I. Apparecchi con conduttore di protezione. ES Clase de aislamiento I. luminarias con conexión a tierra. FR Classe de protection I. Luminaires à borne de mise à la terre.</p>		<p>DE Die Netzanschlussleitung muss immer außer Reichweite von Kindern verlegt werden. EN The power cord must always be kept out of the reach of children. IT Il cavo di collegamento alla rete va condotto sempre fuori dalla portata dei bambini. ES El cable de conexión a la red debe mantenerse siempre fuera del alcance de los niños. FR Le cordon d'alimentation doit toujours être posé de manière à être hors de portée des enfants.</p>
	<p>DE Schutzklasse II. Leuchte mit verstärkter oder doppelter Isolierung, kein Schutzleiteranschluss vorhanden. EN Protection class II. Luminaire with reinforced or double insulation, no protective earth connection available. IT Classe isolamento II. Apparecchio con isolamento doppio o rinforza to, senza conduttore di protezione. ES Clase de aislamiento II: luminaria con aislamiento reforzado o doble sin conexión a tierra. FR Classe de protection II. Luminaire à isolation renforcée ou doublée, pas de borne de mise à la terre.</p>	 OFF	<p>DE Leuchte ausschalten vor dem An- und Abschließen der LED. EN Switch off luminaire before connecting or disconnecting the LED. IT Spegner l'apparecchio prima di collegare e scollegare i LED. ES Muy importante: apague la luminaria antes de conectar o desconectar el LED. FR Eteindre le luminaire avant la connexion et la déconnexion de la LED.</p>
	<p>DE Schutzklasse III mit SELV Versorgung! EN Protection class III with SELV supply. IT Classe isolamento III con alimentazione SELV! ES Clase de aislamiento III: luminarias alimentadas a baja tensión (SELV/MBTS). FR Classe de protection III à alimentation TBTS!</p>	<p>IP40</p>	<p>DE IP4X Geschützt gegen feste Fremdkörper größer als 1,0 mm. EN IP4X Protected against solid foreign objects larger than 1.0 mm. IT IP4X - protezione da corpi estranei maggiori di 1,0 mm. ES IP4X: protección a impactos de material sólido de tamaño superior a 1,0 mm. FR IP4X Protégé contre des corps étrangers solides supérieurs à 1,0 mm.</p>
	<p>DE Vorsicht, Gefahr eines elektrischen Schlages! EN Caution, danger of electric shock! IT Attenzione, pericolo di scossa elettrica! ES Cuidado; ¡peligro de descarga eléctrica! FR Attention, risque de décharge électrique!</p>		<p>DE Nur zur Verwendung in Innenräumen. EN For indoor use only. IT Per uso esclusivo in ambienti interni. ES Solo para el uso en espacios interiores. FR A utiliser uniquement en intérieur.</p>
	<p>DE Handschuhe benutzen. EN Use gloves. IT Indossare guanti. ES Utilizar guantes. FR Porter des gants.</p>		<p>DE Sicherheitshinweis: Es muss sichergestellt werden, dass das DALI-Signal SELV (safety extra low voltage) konform ist. XAL empfiehlt die Verwendung des XAL DALI SELV-Device. EN Safety note: Ensure that the DALI signal is SELV (safety extra-low voltage) compliant. XAL recommends the XAL DALI SELV device. IT Avvertenza si sicurezza: occorre accertarsi che il segnale DALI SELV (safety extra low voltage) sia conforme. XAL raccomanda di utilizzare un device XAL DALI SELV. ES Nota de seguridad: asegúrese de que la señal DALI sea compatible con SELV (Safety Extra Low Voltage: baja tensión de seguridad). XAL recomienda el uso del dispositivo XAL DALI SELV. FR Consigne de sécurité: il est nécessaire de s'assurer que le signal DALI est conforme à la TBTS (très basse tension de sécurité). XAL recommande d'utiliser le dispositif TBTS DALI XAL.</p>
	<p>DE Nicht zur Abdeckung mit Wärmedämm-Material geeignet. EN Not suitable for covering with thermal insulation material. IT Non idoneo alla copertura con materiale termoisolante. ES No cubrir con material de aislamiento térmico. FR Non conçu pour être revêtu d'un matériau d'isolation thermique.</p>		<p>DE Sicherheitshinweis: Es muss sichergestellt werden, dass der verwendete Konverter ein SELV-Konverter mit einem U_{out} max. von 60V oder weniger ist! EN Caution: Ensure that the converter used is a SELV converter with a U_{out} max. of 60V or less. IT Avvertenza di sicurezza: occorre accertarsi che il converter utilizzato sia un converter SELV con U_{out} di max. 60V o meno! ES Nota de seguridad: asegúrese de que el driver utilizado sea un convertidor SELV con una tensión de salida máxima o igual a 60V. FR Consigne de sécurité: il est nécessaire de s'assurer que le convertisseur utilisé est un convertisseur TBTS présentant une tension de sortie max. inférieure ou égale à 60V!</p>
	<p>DE Berühren Sie nicht die LED! EN Do not touch the LED! IT Non toccare i LED! ES ¡No toque el LED! FR Ne pas toucher la LED!</p>		
	<p>DE Nicht im Restmüll entsorgen. EN Do not dispose of in residual waste. IT Non smaltire nei rifiuti ordinari. ES No eliminar junto con la basura doméstica. FR Ne pas jeter dans les ordures ménagères.</p>		

DE Wir behalten uns vor, jederzeit Änderungen an unseren Produkten vorzunehmen. Aktuelle Daten stellen wir jederzeit unter www.xal.com zur Verfügung.
EN We reserve the right to make changes to our products at any time. Current data is available at www.xal.com at any time.
IT Ci riserviamo la facoltà di apportare modifiche ai nostri prodotti in qualsiasi momento. Potete consultare gli aggiornamenti sempre sul nostro sito www.xal.com.
ES Nos reservamos el derecho a realizar cambios en nuestros productos en cualquier momento. Los datos actualizados se encuentran a su total disposición en todo momento en www.xal.com.
FR Nous nous réservons le droit d'apporter à tout moment des modifications à nos produits. Les informations actuelles sont disponibles à tout moment sur www.xal.com.

Rev.: 006/2022-06-28