

# SONO | SONO LOOP CEILING

1/8 Abmessungen | Dimensions | Dimensioni | Medidas | Dimensões

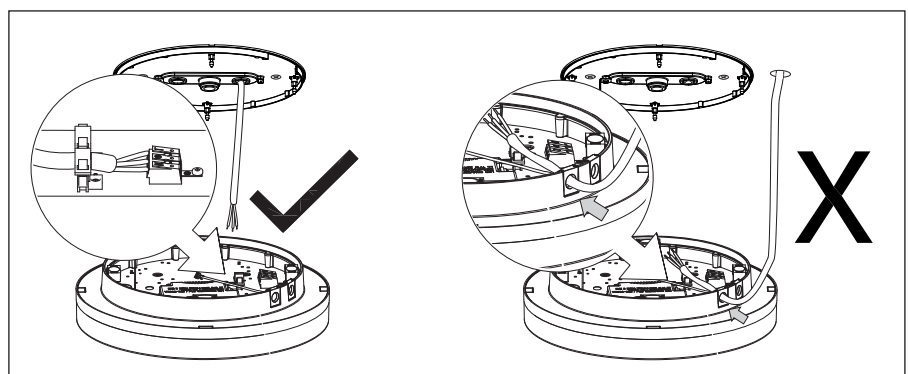
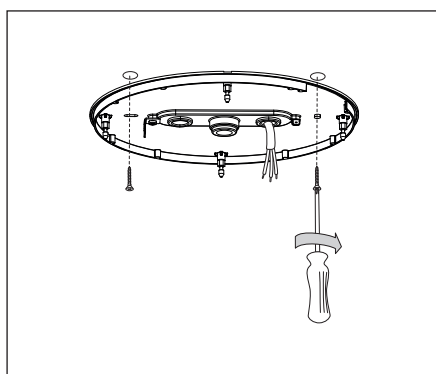
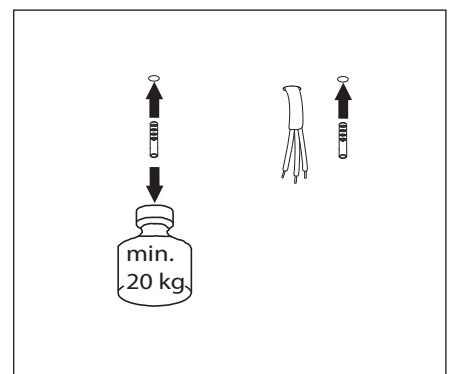
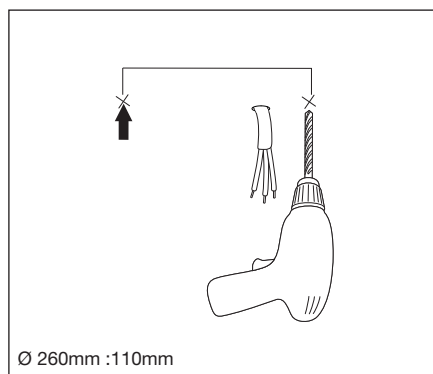
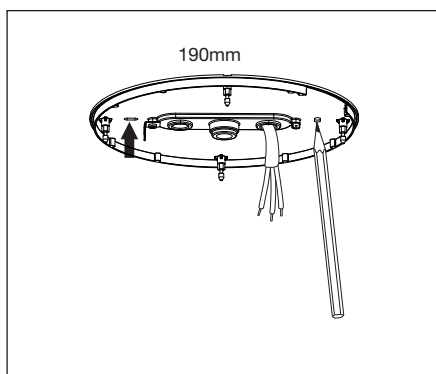
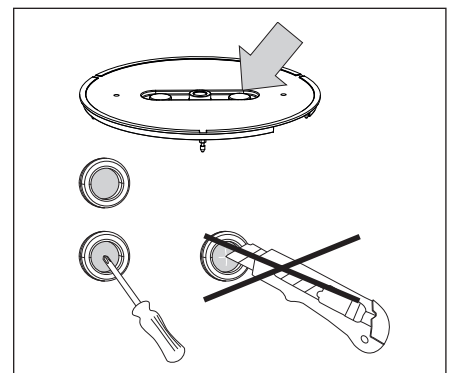
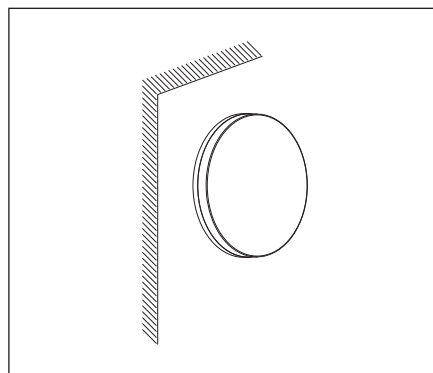
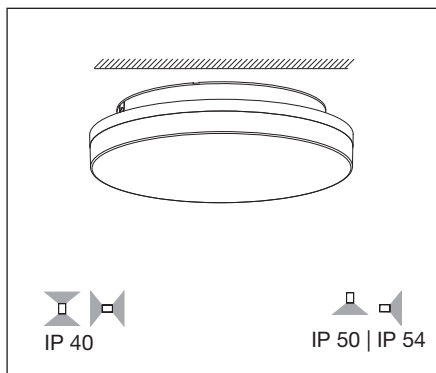
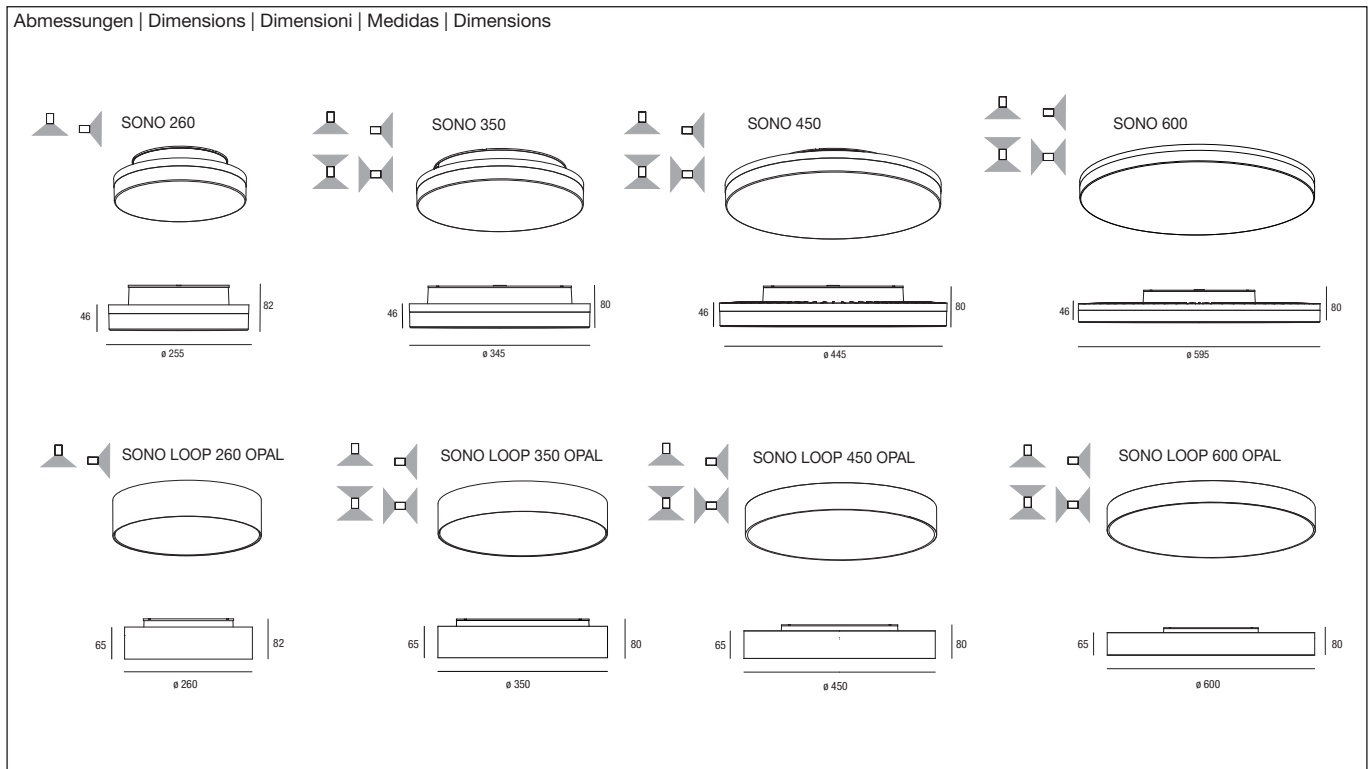

# SONO | SONO LOOP CEILING

Mounting instruction

468071000028

2/8

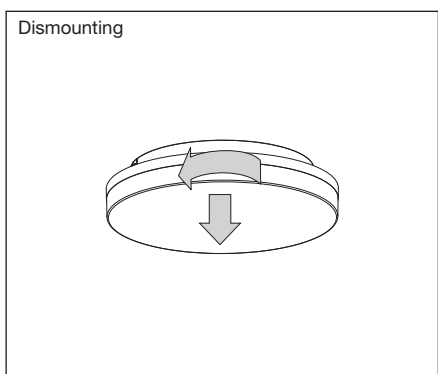
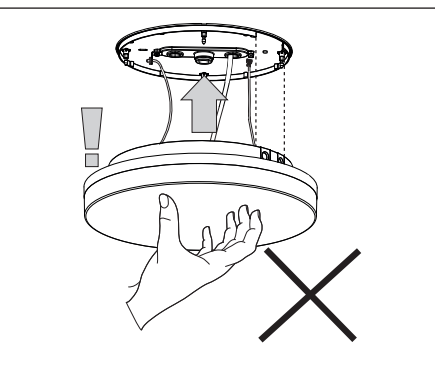
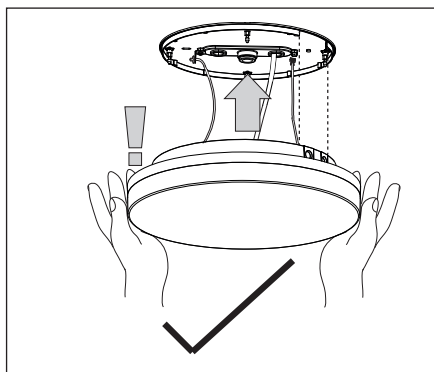
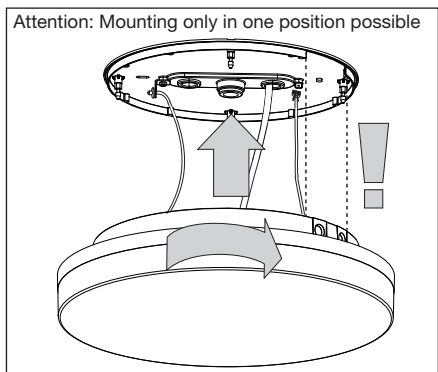
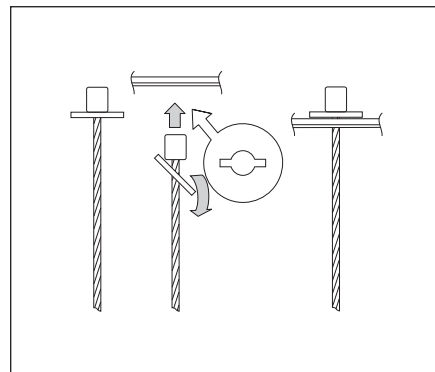
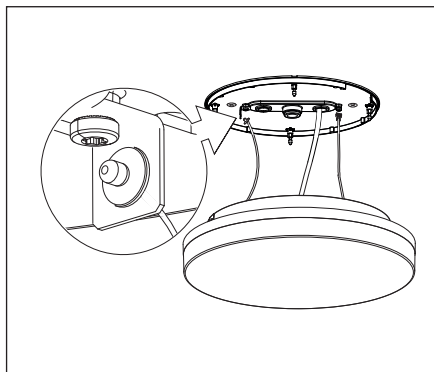
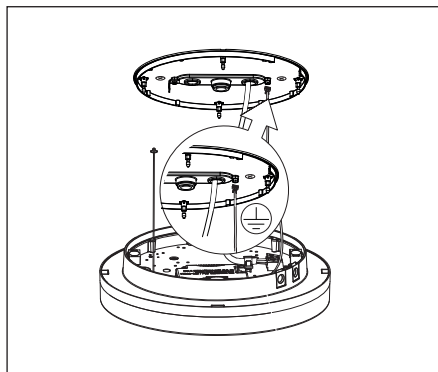

# SONO | SONO LOOP SUSPENDED

Abmessungen | Dimensions | Dimensioni | Medidas | Dimensões

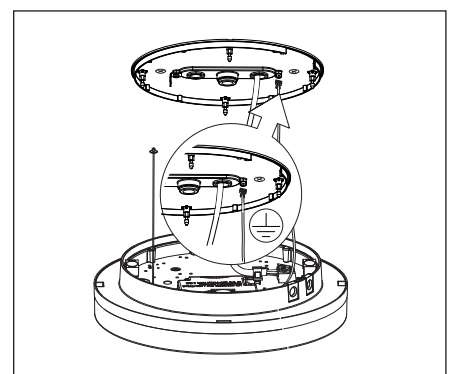
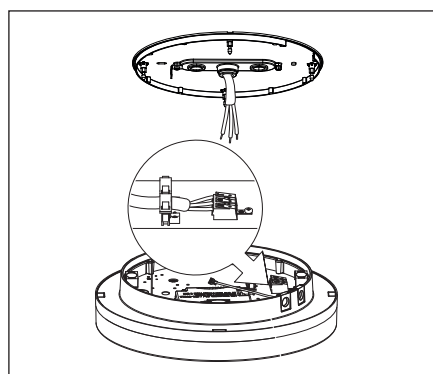
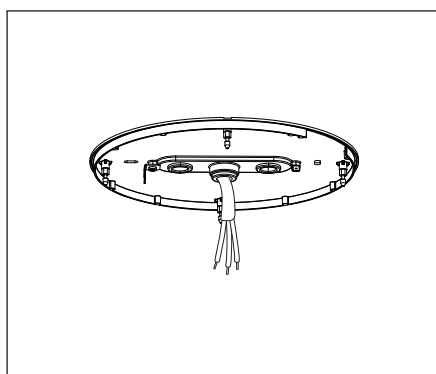
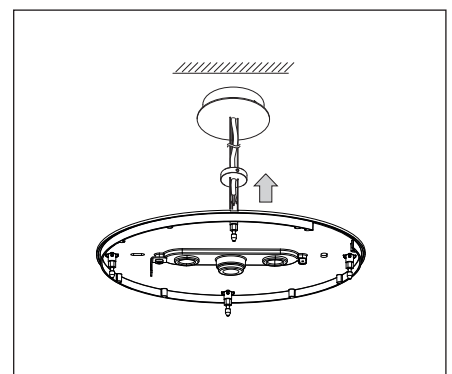
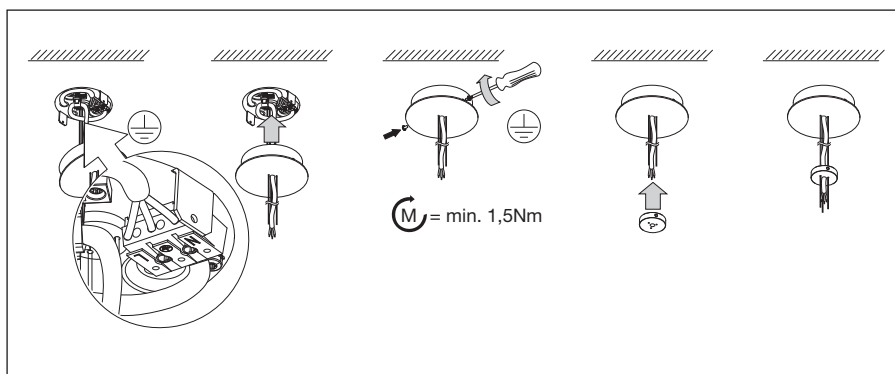
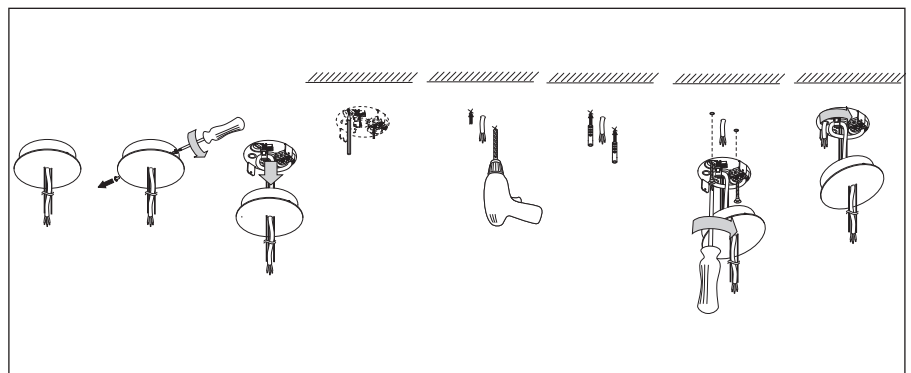
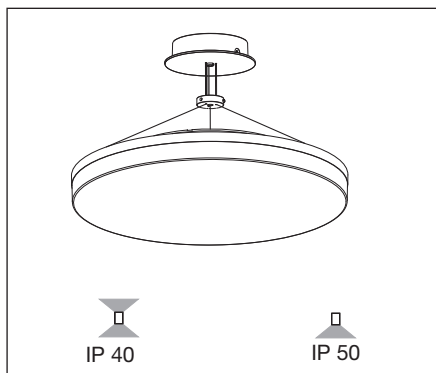
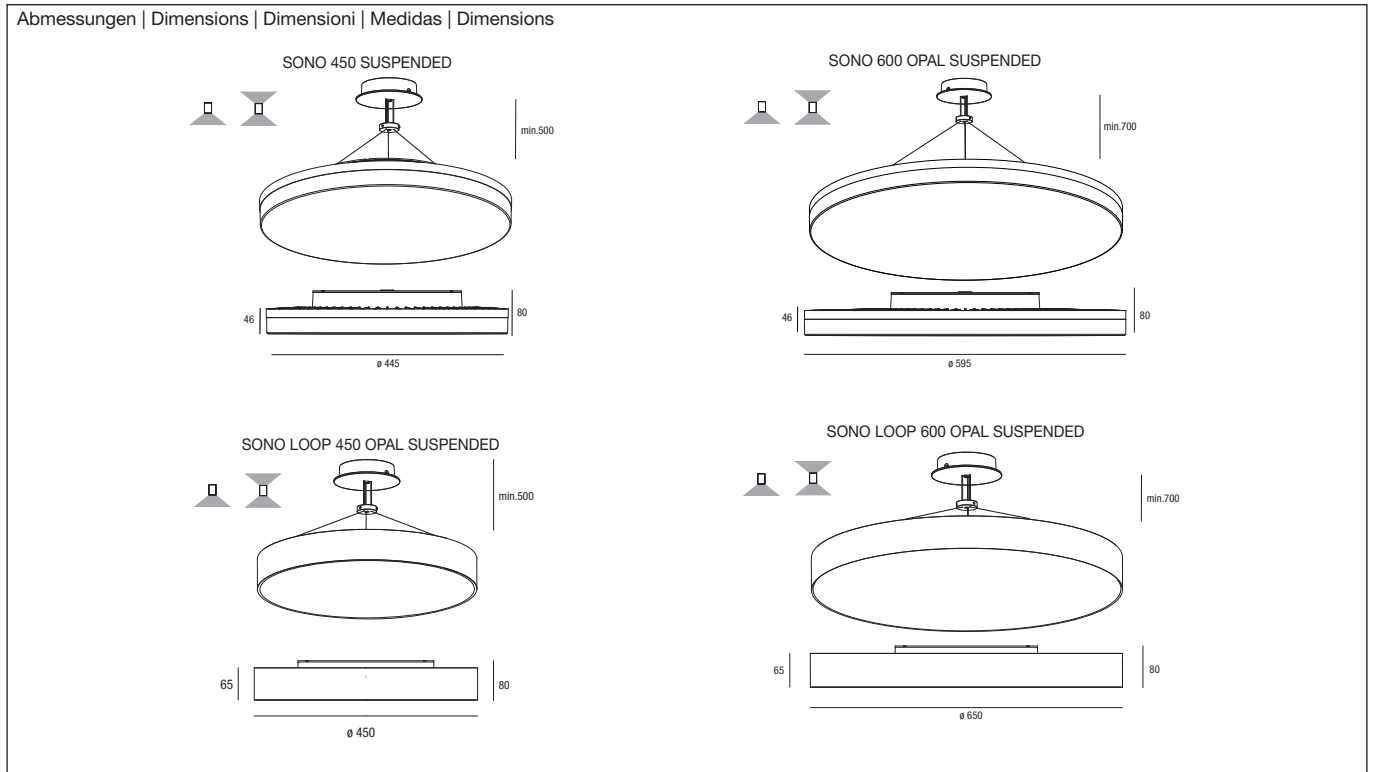

# SONO | SONO LOOP SUSPENDED

Mounting instruction

468071000028

4/8

Attention: Mounting only in one position possible

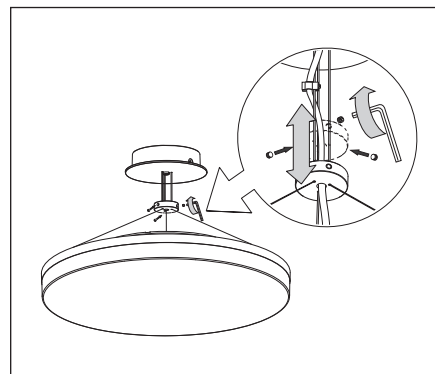
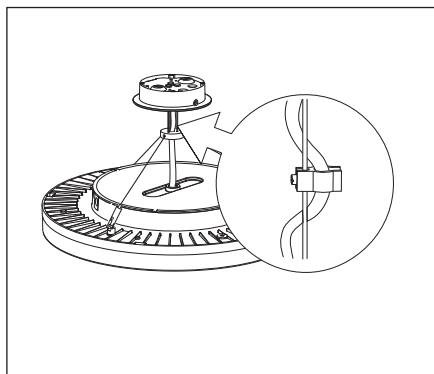
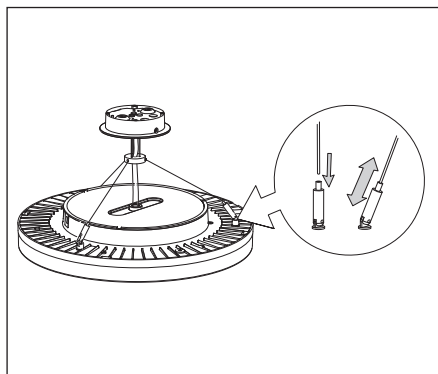
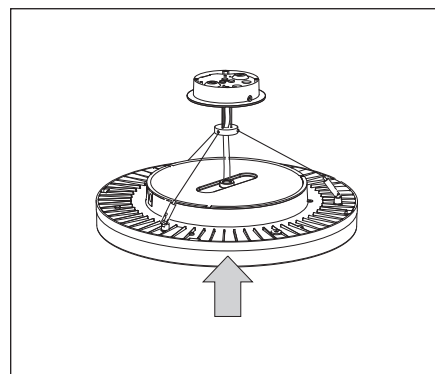
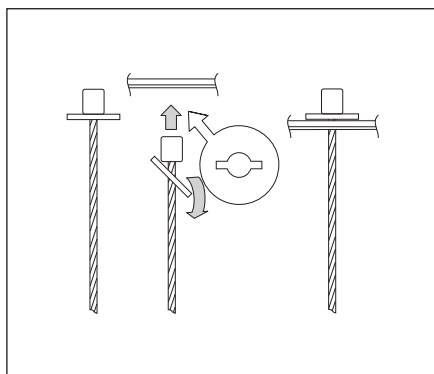
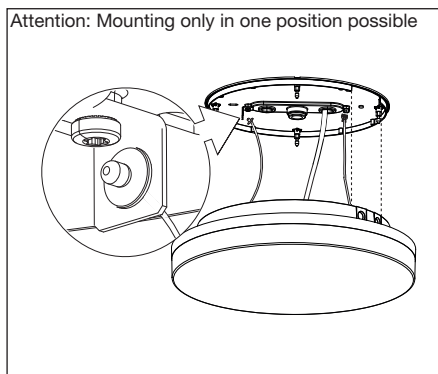

# SONO | SONO LOOP SUSPENDED



Mounting instruction

46807100028

5/8 Abmessungen | Dimensions | Dimensioni | Medidas | Dimensões

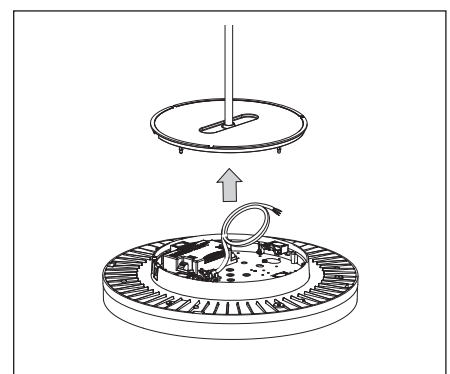
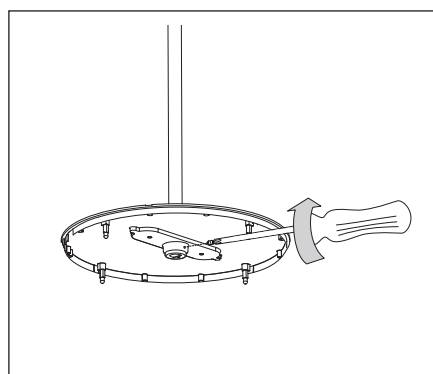
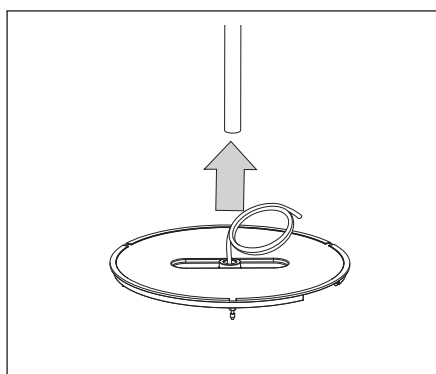
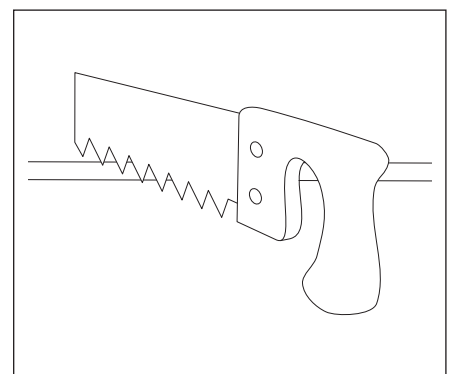
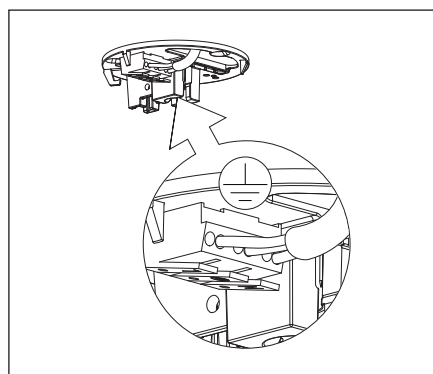
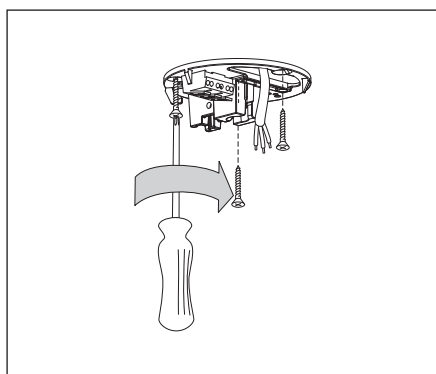
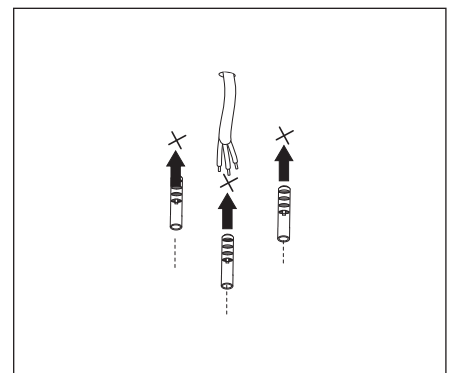
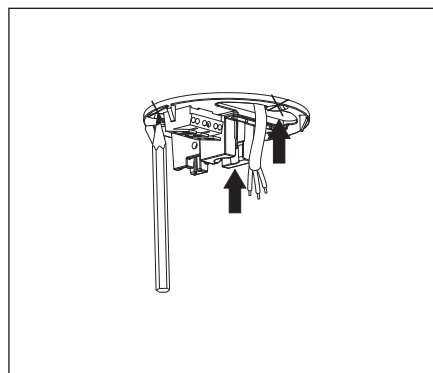
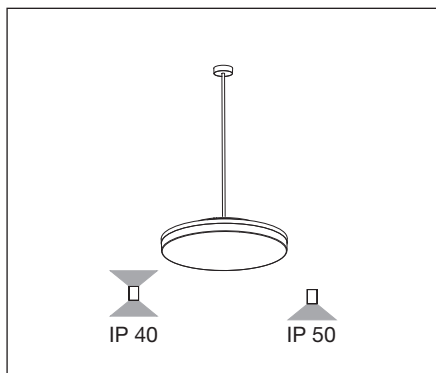
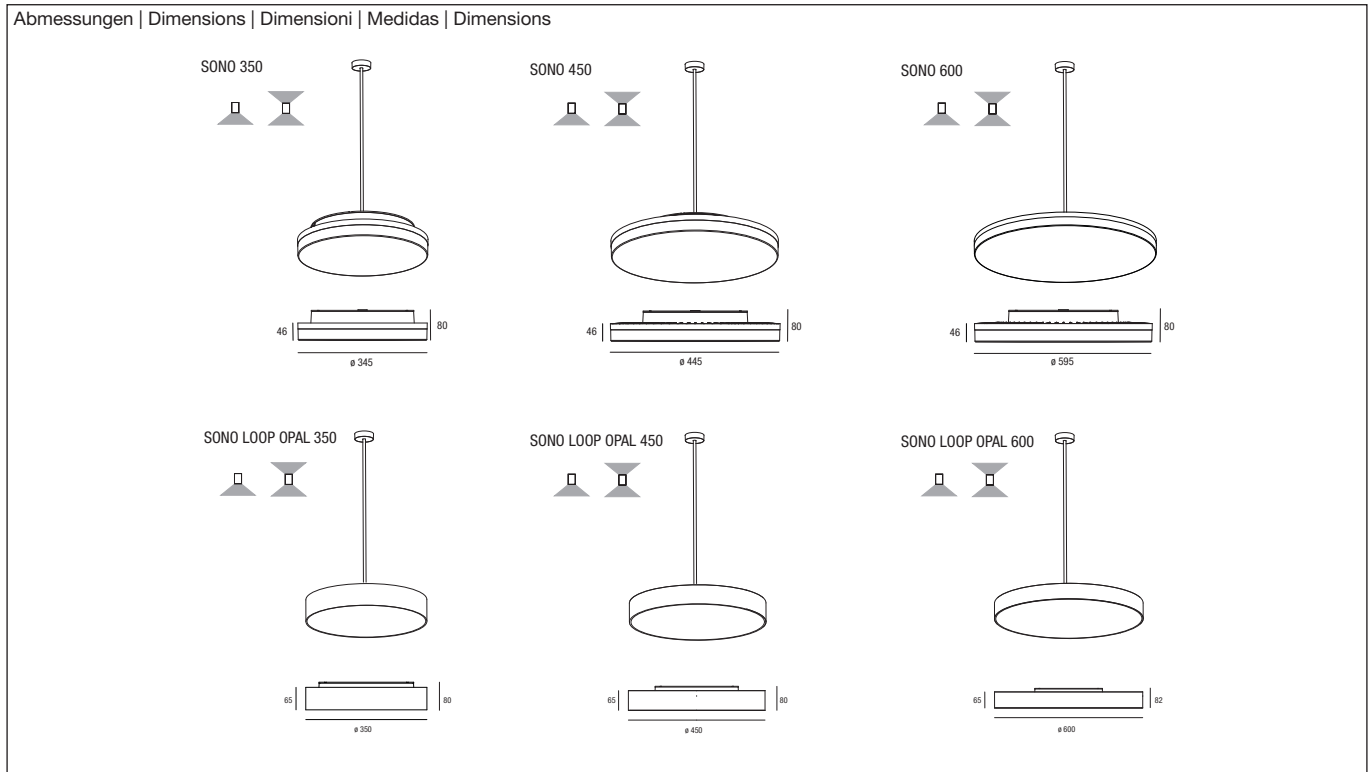

# SONO | SONO LOOP SUSPENDED

Mounting instruction

46807100028

6/8

Attention: Mounting only in one position possible

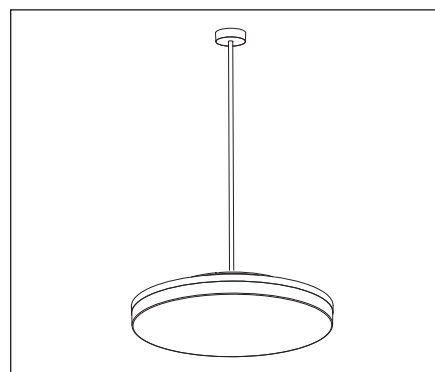
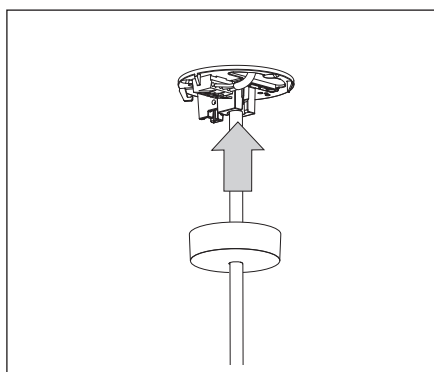
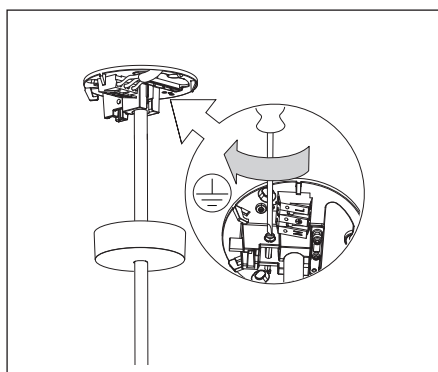
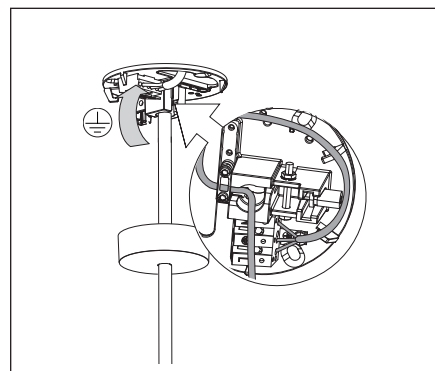
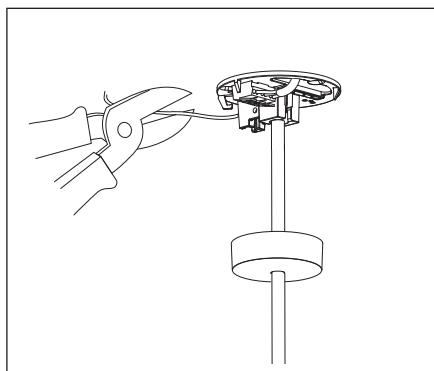
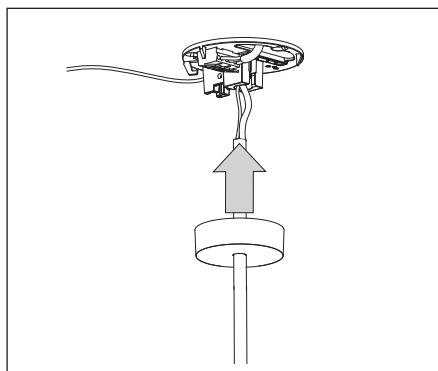
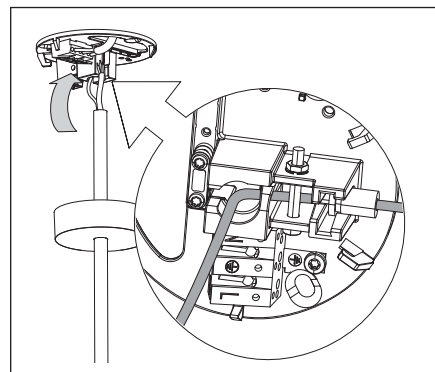
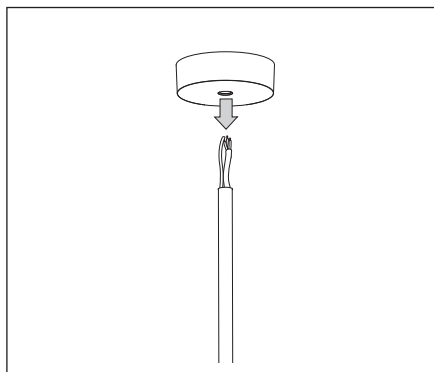
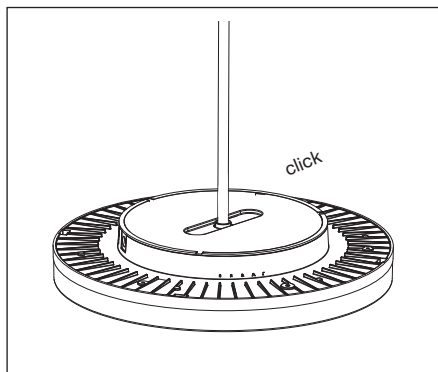
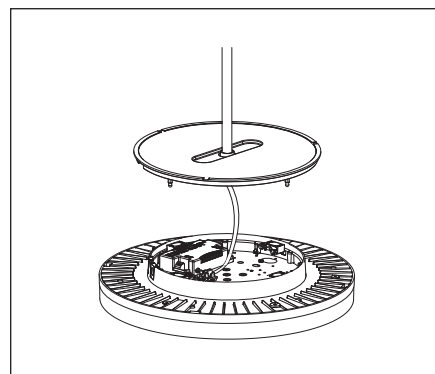
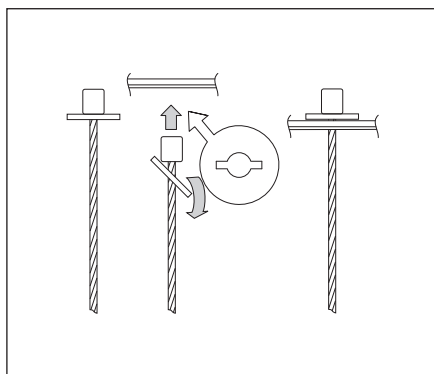
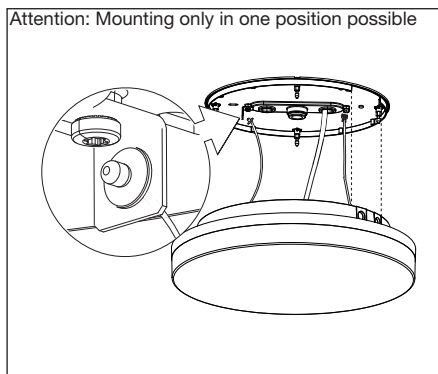

Dismounting

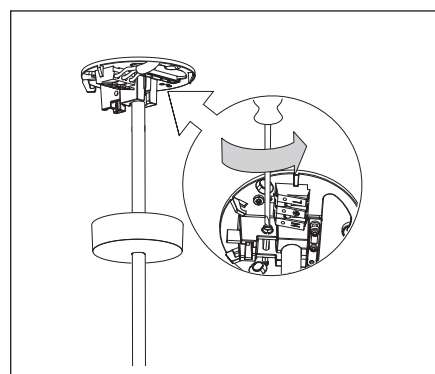
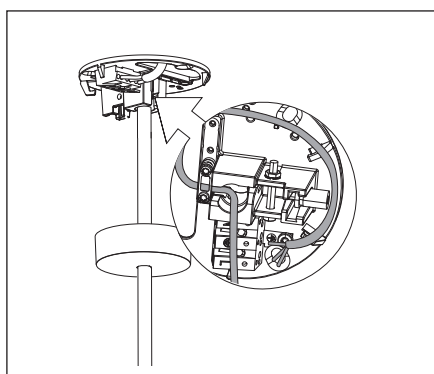
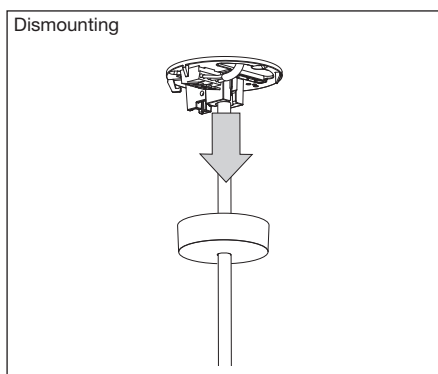

# SONO | SONO LOOP SUSPENDED



Mounting instruction

468071000028

7/8

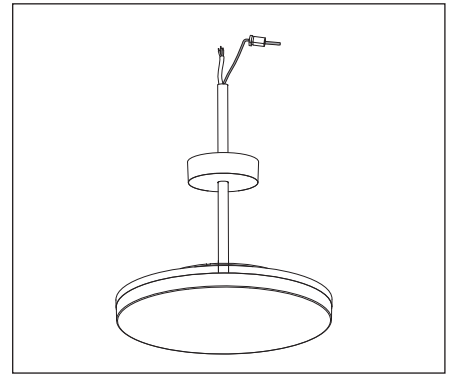
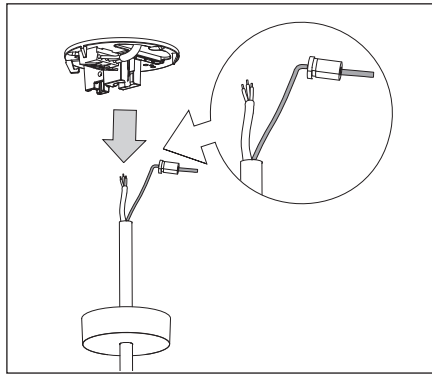
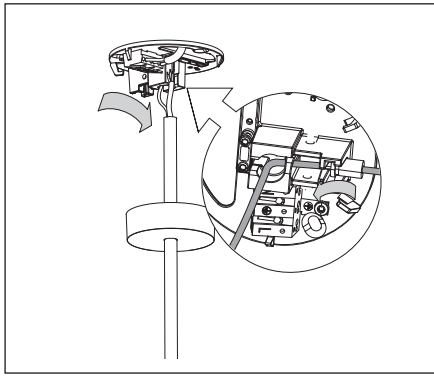

Optional  
Dismounting Rod

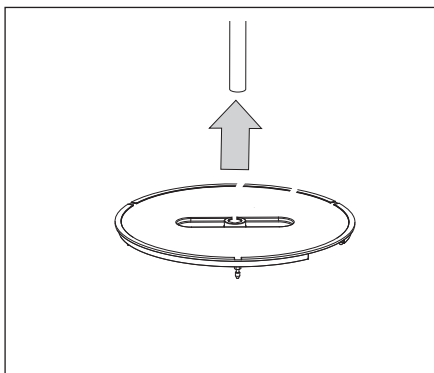
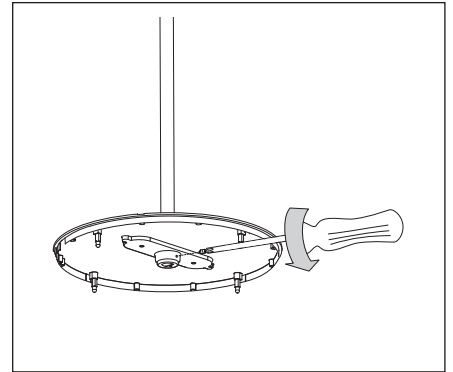
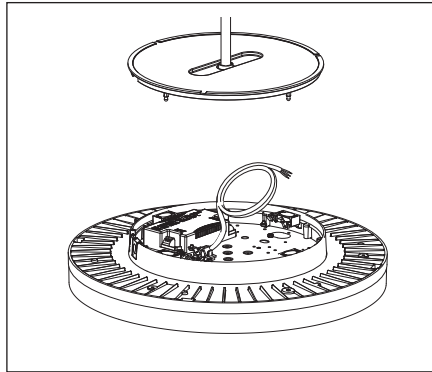
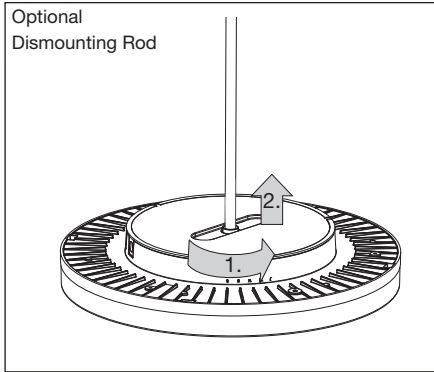

## AFTER SALES SERVICEHOTLINE

Die XAL After Sales – Hotline steht Ihnen telefonisch von Montag bis Freitag von (MEZ) 7:00 bis 20:00 Uhr oder jederzeit per Email zur Verfügung

The XAL After Sales Hotline is available by phone from Monday to Friday from (MEZ) 7:00 a.m. to 8:00 p.m. or 24/7 via email.



**Hotline: +43 316 3170 9400**

**Email: [service@xal.com](mailto:service@xal.com)**

**D** Die Montage, Inbetriebnahme und Wartung darf nur von autorisiertem Fachpersonal unter Berücksichtigung dieser Montageanleitung und aller für den jeweiligen Anwendungsbereich geltenden Normen und Vorschriften durchgeführt werden. Stellen Sie die elektrische, mechanische und thermische Eignung der Leuchte für den vorgesehenen Anwendungsbereich sicher und überprüfen Sie nach der Montage die sichere Befestigung der Leuchte. Schalten Sie vor jedem Leuchtmittelwechsel (falls zutreffend) und vor allen sonstigen Arbeiten an der Leuchte (z.B. Reinigung) die Netzspannung ab und warten Sie bis Leuchte und Leuchtmittel vollständig abgekühlt sind. Berücksichtigen Sie die Montagehinweise des Leuchtmittelherstellers beim Einsetzen, Wechseln und Betreiben konventioneller Leuchtmittel. Verwenden Sie für die Reinigung der Leuchte ein weiches, feuchtes Tuch. Für die Reinigung von Kunststoffteilen und Reflektoren können Sie zusätzlich einen handelsüblichen pH - neutralen, alkoholfreien, nicht scheuernden Reiniger verwenden. Bewahren Sie diese Montageanleitung für allfällige Wartungsarbeiten gut auf.

Die Leuchte (IP 40 , IP 50 ) ist nicht für den Außenbereich geeignet.

Die Leuchte darf nur mit einer Schutzvorrichtung betrieben werden.

Ersetzen Sie unverzüglich beschädigte Schutzgläser bzw. Schutzabdeckungen.

Bei nachträglichen Änderungen an der Leuchte wird keine Haftung übernommen.

LEDs sind hochwertige elektronische Bauteile! Bitte vermeiden Sie während der Montage oder Wartungsarbeiten eine direkte Berührung der LED-Lichtaustrittsfläche mit den Händen.

Die eingebaute Lichtquelle darf nur durch den Erzeuger, dessen Kundendienst oder durch qualifiziertes Fachpersonal getauscht werden.

Der LED-Stromkreis muss immer geschlossen sein, bevor der Konverter an das Netz angeschlossen wird. XAL übernimmt keine Haftung für Schäden bei Nichtbeachtung dieser Vorschrift.

Die Leistung und der Lichtstrom unterliegen initial einer Toleranz +/- 10%. Toleranz der Farbtemperatur +/- 150 Kelvin.

**E** Installation, commissioning and maintenance may only be performed by authorized and qualified personnel, taking into consideration these installation instructions and any standards and regulations applicable to the respective area of application. The electrical, mechanical and thermal suitability of the luminaire for the intended area of application must be ensured and the secure fastening of the luminaire after its installation must be controlled. Turn off supply voltage before replacing any lamps (if applicable) as well as before performing any other works on the luminaire (e.g. cleaning) and wait until luminaire and lamp have completely cooled off. Please refer to the installation notes of the lamp manufacturer when inserting, replacing and operating conventional lamps. Use a soft, damp cloth to clean the luminaire. To clean plastic components and reflectors, a standard pH neutral, alcohol-free, non-abrasive cleaning agent may also be used. Keep these installation instructions in a safe place as reference for any future maintenance works.

The lamp (IP 40 , IP 50 ) is not suitable for outdoor use.

The lamp may only be used with a safety guard.

Damaged protection glasses and covers have to be replaced immediately.

No liability is accepted for any subsequent change of the luminaire.

LEDs are high-quality electronic components! Please avoid touching by hand the LED light emitting surface while assembling or replacing parts and during maintenance work.

The light source contained in this luminaire shall only be replaced by the manufacturer or his service agent or a similar qualified person.

The LED circuit must always be closed, before the converter is connected to the main power. XAL does not assume any liability for damages resulting from nonobservance of this rule.

Luminous flux and connected electrical load are subject to an initial tolerance of up to +/- 10%. Color temperature is subject to a tolerance of up to +/- 150 Kelvin from the nominal value.

**I** Il montaggio, la messa in funzione e la manutenzione possono essere effettuati solo da tecnici autorizzati, nel rispetto delle presenti istruzioni di montaggio e di tutte le norme e disposizioni vigenti per il relativo campo di applicazione. Assicurarsi dell' idoneità elettrica, meccanica e termica della lampada per il campo di applicazione previsto e verificare dopo il montaggio che la lampada sia fissata saldamente. Prima di ogni sostituzione della lampadina (se applicabile) e prima di ogni intervento sulla lampada (ad esempio pulizia) staccare la tensione di rete e aspettare fino al completo raffreddamento della lampada e della lampadina. Rispettare le istruzioni di montaggio del relativo produttore per l'impiego, la sostituzione e l'azionamento della lampadina convenzionale. Per la pulizia della lampada utilizzare un panno morbido e umido. Per la pulizia delle parti in plastica e dei riflettori si può utilizzare inoltre un detergente normale a pH neutro, senza alcool, non abrasivo. Conservare le presenti istruzioni di montaggio in buone condizioni per eventuali interventi di manutenzione.

La lampada (IP 40 , IP 50 ) non è adatta per uso esterno.

La lampada può essere fatta funzionare solamente con un dispositivo di protezione.

Vetri e coperchi di sicurezza danneggiati devono essere sostituiti immediatamente.

Si declina qualsiasi responsabilità per modifiche successive alla lampada.

I LED sono componenti elettronici di elevata qualità! Evitate per favore durante il montaggio, la sostituzione e lavori di manutenzione il contatto diretto con le mani della superficie di uscita della luce LED.

La sorgente luminosa in questo apparecchio deve solo essere sostituita dal produttore, dall'assistenza tecnica o una persona simile qualificata.

Il circuito LED deve sempre essere chiuso prima che il convertitore venga allegato alla spina. XAL non si prende la responsabilità per eventuali danni se questa regola non viene rispettata.

I dati di flusso luminoso e potenza sono inizialmente passibili di tolleranze di +/- 10%. Tolleranza della temperatura di colore: +/- 150 Kelvin.

**S** La instalación, la puesta en marcha y el mantenimiento sólo deben realizarse por personal especializado considerando esta guía de instalación y todas las normas y reglamentaciones vigentes. Asegurarse de la aptitud eléctrica, mecánica y térmica de la luminaria para la aplicación prevista y comprobar la fijación segura de la luminaria después de su instalación. Apagar siempre la corriente antes de cambiar la lámpara (en caso justificado) o de realizar algún otro trabajo en esta (p.ej. Limpieza). Esperar hasta que se enfíen la luminaria y la lámpara completamente. Tener en cuenta las instrucciones de montaje del fabricante al colocar, cambiar y utilizar lámparas convencionales. Para la limpieza de la luminaria utilizar un paño suave y húmedo. Para limpiar componentes de plástico y reflectores puede usar también un limpiador pH neutral y sin alcohol que no roce el material. Guardar esta guía de instalación para trabajos de mantenimiento.

La luminaria (IP 40 , IP 50 ) no es apta para utilizarla en el exterior.

La luminaria sólo debe accionar con un dispositivo de seguridad.

Cambie de inmediato los vidrios y las tapas de protección dañados.

Para modificaciones futuras en la luminaria no se asume ninguna responsabilidad.

Los LED son componentes electrónicos de alta calidad! Por favor durante el montaje o el mantenimiento evite el contacto directo con la superficie de emisión.

La fuente luminosa contenida en esta luminaria debe ser reemplazada únicamente por el fabricante o su agente de servicio o similar persona cualificada.

El circuito LED debe ser cerrado antes de conectar el convertidor. XAL no asume garantía si esta norma no se respeta.

I dati di flusso luminoso e potenza sono inizialmente passibili di tolleranze di +/- 10%. Tolleranza della temperatura di colore: +/- 150 Kelvin.

**F** Le montage et la maintenance peut être effectué par spécialistes respectant les norms y règles valides. Assurer l'aptitude thermique, mécanique et électrique pour l'emploi prévue et assurer la fixation de la luminare. Attendre la tension avant de changer les lampes (si applicable) ou avant de réaliser travaux (p.ex nettoyage) a la luminare. Attendre jusqu'à ce que la luminare et les lampes ont fraîchit complètement. Merci de bien vouloir vous référer aux notes d'installation du fabricant de la lampe lors de l'insertion, le remplacement et la mise en route, avec des lampes conventionnelles. Pour nettoyer la luminare utiliser un drap humide et doux. Pour nettoyer les parties du plastique ou les réflecteurs on peut utiliser encore un produit de nettoyage sans alcool qui ne fraye pas le material. Garder cette notice de montage pour possibles travaux de maintenance.

La luminare n' (IP 40 , IP 50 ) est pas apte pour l'utilizage extérieur.

Utilizer la luminare seulement avec un dispositif de sécurité

Changer immédiatement des verres de sécurité defectes ou bien des écrans de protection.

Nous déclinons toute responsabilité en cas de modifications ultérieures.

Des LEDs sont des composants électroniques de haute qualité! Eviter tout contact direct de la surface de sorti de lumière de la LED avec les mains lors du montage ou des les travaux de maintenance de la lampe.

Il faut que le circuit de LED soit fermé avant de connecter le convertisseur. XAL ne assume pas la garantie si cette norme ne se respecte pas.

La puissance et le flux lumineux affiché d'origine une tolérance de +/-10 %. Tolérance de la couleur de température : +/- 150 Kelvin.



Schutzklasse 1: Leuchten mit Schutzleiteranschluss.  
Protection class 1: Lights with ground wire connection.  
Categoría di protezione 1: lampade con attacco conduttore di protezione.

220-240V

Grado de protección 1: Luminarias con toma de tierra.  
Classe de protection 1: Luminaires avec raccordement de conducteur de protection.

**IP 50**

IP50 Abgedeckt.  
IP50 Covered.  
IP50 Coperto.  
IP50 Cubierta.  
IP50 Recouvert.

**IP 40**

IP4X Geschützt gegen feste Fremdkörper größer als 2,5mm | IPX4 Spritzwassergeschützt.  
IP4X Protection against penetration of foreign objects, larger than 2,5mm | IPX4 Splash-proof.  
IP4X Protetto contro corpi solidi estranei maggiori di 2,5mm | IPX4 Protezione antispruzzo.  
IP4X Protegida contra el ingreso de objetos solidos con un tamaño superior a 2,5mm | IPX4 Protegida contra chorros de agua.  
IP4X Protégé contre les corps solides étrangers de diamètre supérieur à 2,5 mm | IPX4 Protégé contre les projections d'eau.

**IP 54**

IP5X Staubgeschützt | IPX4 Spritzwassergeschützt.  
IP5X Dust-proof | IPX4 Splash-proof.  
IP5X Protezione antipolvere | IPX4 Protezione antispruzzo.  
IP5X Protegida contra polvo | IPX4 Protegida contra chorros de agua.  
IP5X Protégé contre la poussière | IPX4 Protégé contre les projections d'eau.

**t<sub>a</sub> -20 - +50°C:**

Höchste Bemessungs-Umgebungstemperatur.  
Maximum rated ambient temperature.  
Massima temperatura ambiente asignada.  
Máxima temperatura ambiente asignada.  
Température assignée et ambiante maximale.

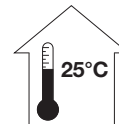

Empfohlene Raumtemperatur: 25 °C.  
Recommended room temperature: 25 °C.  
Temperatura ambiente consigliata: 25 °C.  
Temperatura ambiente recomendada: 25 °C.  
Température ambiante recommandée: 25 °C.



**D** Vorsicht Spannung ! Die eingebaute Lichtquelle darf nur durch den Erzeuger, dessen Kundendienst oder durch qualifiziertes Fachpersonal getauscht werden.  
**E** Caution, electric shock ! The light source contained in this luminaire shall only be replaced by the manufacturer or his service agent or a similar qualified person.  
**I** Attenzione, voltaggio alto! La sorgente luminosa in questo apparecchio deve solo essere sostituita dal produttore, dall'assistenza tecnica o una persona simile qualificata.  
**ES** Precaución, descargas eléctricas! La fuente luminosa contenida en esta luminaria debe ser reemplazada únicamente por el fabricante o su agente de servicio o similar persona cualificada.  
**F** Attention, risque de choc électrique ! La source du luminaire peut être remplacé uniquement par le fabricant ou un tiers habilité.



Don't touch the LED !

Wir behalten uns vor, jederzeit Änderungen an unseren Produkten vorzunehmen. Aktuelle Daten stellen wir jederzeit unter [www.xal.com](http://www.xal.com) zur Verfügung.

We reserve the right to change our products at any time. Current information is available at [www.xal.com](http://www.xal.com).

Ci riserviamo la possibilità di apportare modifiche ai nostri prodotti in qualsiasi momento. I dati aggiornati sono disponibili all'indirizzo Internet: [www.xal.com](http://www.xal.com).

Nos reservamos en todo momento el derecho de realizar cambios en nuestros productos. n nuestra página web [www.xal.com](http://www.xal.com) siempre se encontrarán datos actuales.

Nous nous réservons le droit de modifier à tout moment nos produits. Vous trouverez toujours toutes les informations actuelles sur [www.xal.com](http://www.xal.com).